



**THE SIMULATION PLATFORM FOR  
POWER ELECTRONIC SYSTEMS**

**TI C2000 Target Support User Manual** Version 2.3.2

## How to Contact Plexim:

☎	+41 44 533 51 00	Phone
	+41 44 533 51 01	Fax
✉	Plexim GmbH Technoparkstrasse 1 8005 Zurich Switzerland	Mail
@	info@plexim.com	Email
	<a href="http://www.plexim.com">http://www.plexim.com</a>	Web

### *TI C2000 Target Support User Manual*

© 2024 by Plexim GmbH

The product described in this manual is furnished under a license agreement. The software may be used or copied only under the terms of the license agreement. No part of this manual may be photocopied or reproduced in any form without prior written consent from Plexim GmbH.

PLECS is a registered trademark of Plexim GmbH. MATLAB, Simulink and Simulink Coder are registered trademarks of The MathWorks, Inc. Bonjour is a registered trademark of Apple, Inc. Other product or brand names are trademarks or registered trademarks of their respective holders.

# Contents

<b>Contents</b>	<b>iii</b>
<b>1 Quick Start</b>	<b>3</b>
Requirements for TI C2000 TSP 2.3.2 . . . . .	3
Install the Target Support Package . . . . .	3
Using the Installer Executable . . . . .	3
Manual Installation . . . . .	4
Build and Flash Configuration Settings . . . . .	5
Program the MCU from PLECS . . . . .	5
Program the MCU from CCS . . . . .	8
Start the External Mode . . . . .	9
Troubleshooting Guide . . . . .	10
Tips for Programming C2000 Development Kits . . . . .	11
External mode GPIO pins . . . . .	11
TI28003x . . . . .	12
TI28004x . . . . .	14
TI2806x . . . . .	16
TI2833x . . . . .	18
TI2837x . . . . .	18
TI2838x . . . . .	20
TI28P55x . . . . .	21
TI28P65x . . . . .	23

TI29H85x . . . . .	26
TI C2000 Target Support and the PLECS RT Box . . . . .	27
<b>2 C2000 Target Support Architecture</b>	<b>29</b>
Overview . . . . .	29
The Embedded Code Generation Workflow . . . . .	29
Control Task Execution . . . . .	30
Control Task Accuracy and PWM Frequency Tolerance . . . . .	31
Explicit and Implicit Trigger Definitions . . . . .	32
Multi-Tasking and Dual-Core Execution . . . . .	40
Multi-tasking Operation . . . . .	40
Dual-core Operation . . . . .	42
The Code Generation Project . . . . .	44
<b>3 TI C2000 Coder Options</b>	<b>47</b>
General . . . . .	47
PGA . . . . .	48
PWM . . . . .	48
Protections . . . . .	48
ADC . . . . .	50
External Mode . . . . .	50
<b>4 TI C2000 Target Support Library Component Reference</b>	<b>51</b>
ADC . . . . .	52
CAN Port . . . . .	55
CAN Receive . . . . .	59
CAN Transmit . . . . .	61
Comparator . . . . .	63
Control Task Trigger . . . . .	65
CSV . . . . .	66
CPU Load . . . . .	68
DAC . . . . .	69

---

Digital In . . . . .	70
Digital Out . . . . .	71
External Sync . . . . .	72
Offline Inport . . . . .	73
Offline Outport . . . . .	74
Override Probe . . . . .	75
Peak Current Controller . . . . .	76
Powerstage Protection . . . . .	80
Pulse Capture . . . . .	85
PWM . . . . .	88
PWM (Variable) . . . . .	94
Quadrature Encoder Counter (QEP) . . . . .	101
Read Probe . . . . .	102
Serial . . . . .	103
Sigma-Delta Filter Module . . . . .	104
Configuration . . . . .	104
Filtering . . . . .	105
Comparator . . . . .	106
Offline Only . . . . .	107
SPI Controller . . . . .	108
SPI Peripheral . . . . .	113
Timer . . . . .	115



# Quick Start

## Requirements for TI C2000 TSP 2.3.2

The PLECS Texas Instruments (TI) C2000 Target Support Package supports the TI 2806x, 2833x, 2837x, 2838x, 28003x, 28004x, 28P55x, 28P65x, and 29H85x microprocessors.

In order to use the PLECS TI C2000 Target Support Package you will need:

- a host computer (with Microsoft Windows or Mac OS X),
- PLECS Blockset or Standalone 5.0.1 or newer
- PLECS Coder
- UniFlash for TI microcontrollers v9.2.0 or newer
- C2000 Code Gen Tools (C2000-CGT) v22.6.0.LTS or newer
- C29 Clang Code Gen Tools (C29-CGT) v1.0.0.LTS or newer <sup>1</sup>

If you have not done so yet, please download and install the latest PLECS release on your host computer.

## Install the Target Support Package

For installation on Windows, using the Installer Executable is highly recommended. For other platforms, the manual installation process must be followed.

### Using the Installer Executable

Download the Installer Executable from the web page [https://www.plexim.com/download/tsp\\_c2000](https://www.plexim.com/download/tsp_c2000), and double click on it to

---

<sup>1</sup>Not required for C28 targets

start the setup of the TI C2000 Target Support Package. Choose the desired location to install the files and select the desired installation type to proceed with the setup.

Choosing Compact Installation would only install the tools required for core functionality; these include the TI C2000 Target Support Package and the PLECS RT Box Target Support Package. Whereas, choosing Full Installation would download and install all the the necessary tools required to build and program the TI MCU from PLECS, including the auxiliary TI tools, described in the section below.

## Manual Installation

Download the appropriate ZIP archive from the web page [https://www.plexim.com/download/tsp\\_c2000](https://www.plexim.com/download/tsp_c2000), extract it and move the ti\_c2000 folder to the PLECS Coder target support packages path e.g. to HOME/Documents/PLECS/CoderTargets. In PLECS, choose **Preferences...** from the **File** drop-down menu (**PLECS** menu on Mac OS X) to open the PLECS Preferences dialog.

Navigate to the **Coder** tab and click on the **Change** button to select the HOME/Documents/PLECS/CoderTargets folder. The targets included as part of the TI C2000 Target Support Package should now be listed under **Installed targets**. You will also see these targets available in the **Coder + Coder options...** window in the drop-down menu on the **Target** tab.

Another folder labeled projects is included in the ZIP archive. The contents of this folder is required only when the PLECS Coder is configured to generate code into a Code Composer Studio (CCS) project. The projects/28xx.zip files contain CCS projects that are used in conjunction with the embedded code generated from PLECS.

A set of basic demos is also included with the TI C2000 Target Support Package. Most of these demos use the PLECS RT Box to perform hardware-in-the-loop testing of the generated code. Therefore, the PLECS RT Box Target Support Package should be installed and configured. The RT Box Target Support Package can be downloaded from [https://www.plexim.com/download/rt\\_box](https://www.plexim.com/download/rt_box). The PLECS RT Box hardware is not required to generate and run microcontroller (MCU) code or to run the demo models offline in PLECS Blockset and Standalone.

# Build and Flash Configuration Settings

There are two primary methods to deploy generated embedded code onto a TI C2000 MCU. Both methods use free tools available from TI. You must download these tools from the TI website as they are not provided with your PLECS installation.

**1 Build and program the MCU from PLECS** You can directly program the target device from the PLECS application. This approach requires two standalone utilities available from TI: C2000 Code Gen Tools (CGT) and UniFlash. The C2000 CGT includes a compiler, assembler, linker, and additional tools to build C/C++ applications for the TI C2000 family of MCUs. UniFlash is a tool to program the on-chip flash memory of TI MCUs. Clicking **Build** in the Coder Options dialog generates model C code, builds the application using C2000 CGT, and then flashes the embedded target using UniFlash.

**2 Build and program the MCU from CCS** In this approach the PLECS Coder generates embedded C code for the specified target into a template CCS project. The CCS application is then used to build the project and flash the target device. The advantage of this method is having access to CCS's debugging tools.

If the required software is installed on your PC you can easily switch between the two methods by changing the **Build type** parameter in the **Coder options... + Target + General** menu.

## Program the MCU from PLECS

### Configuring TI Code Gen Tools and UniFlash

If “Full Installation” was performed using the Installer Executable the setup process earlier, then these tools should be installed and configured. To manually configure these tools, download and install the following versions of C2000 Code Gen Tools and UniFlash, available online:

UniFlash v9.2.0: <https://www.ti.com/tool/download/UNIFLASH>  
C2000-CGT v22.6.0.LTS: <https://www.ti.com/tool/download/C2000-CGT-C29-CGT-v1.0.0.LTS>

To configure the PLECS Coder to use the external TI tools, select **Preferences...** from the **File** drop-down menu (**PLECS** menu on Mac OS X) to open

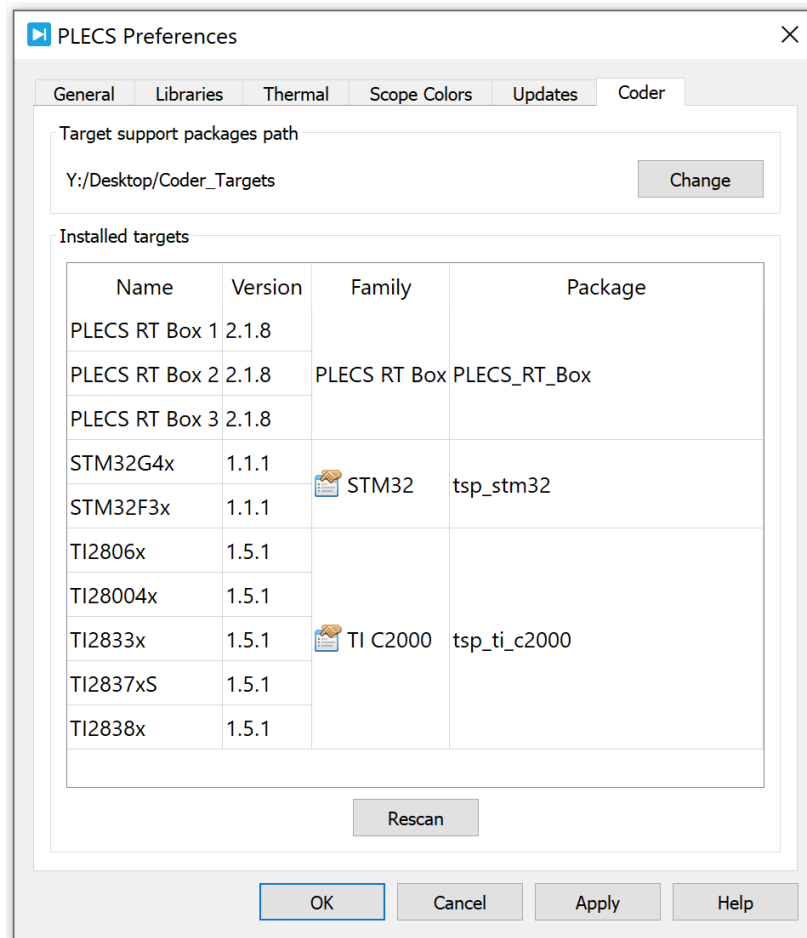

**Figure 1.1: Configuring the target support package and external tool paths**

the PLECS Preferences dialog. Click the **Coder** tab to see the installed targets. There is a icon next to the **TI C2000** entry in the **Family** column indicating the external tools are not yet configured. After clicking the icon a dialog will appear where the user can enter the installation directories of the C2000 CGT and UniFlash tools. Once the installation directories are entered, you will see a icon in the **Family** column, as shown in Figure 1.1.

## Deploy code to C2000 target from PLECS

To deploy code to a C2000 target from PLECS, navigate to the PLECS **Coder Options + Target** window, select the target MCU, then set the **Build type** to Build and program. There is a choice to select either Run from Flash or Run from RAM as the **Build configuration**. If using a Launchpad or a ControlCard as the **Board** type, select the appropriate one from the dropdown menu, and click **Build** to build, program and execute the generated code on the C2000 target.

If using a Custom **Board** instead, you need to first generate the target configuration file once for a specific MCU. All information required to program the MCU is contained in the target configuration file. Target configuration files establish the basic communication settings for the MCU. Target configuration files have a `ccxml` extension and can be generated automatically from the UniFlash tool graphical user interface.

Open the UniFlash application and create a new configuration based on your selected device and connection method. Click the **Start** button after modifying any additional configuration options. After clicking **Start** you will now see a link to download the `ccxml` file near the top of the window.

After downloading the target configuration file navigate back to the PLECS **Coder Options + Target** window, set the **Board** field to Custom. The **UniFlash target configuration** field will now be visible. Enter the path to the `ccxml` file downloaded from UniFlash.

Modify any additional settings for your chosen target in the **Coder Options** window, including enabling or disabling the External Mode, and then click **Build**. This will automatically build the code, program the MCU, and start executing the generated code. Note that this programming method requires that only one TI C2000 MCU is connected to your host PC.

In the event there is an error in programming the MCU, the PLECS diagnostics window will contain additional debugging information. The diagnostics window is accessible from the exclamation icon in the lower right hand corner of any PLECS schematic window.

## Program the MCU from CCS

### Configuring CCS

Download and install CCS v12.x from the TI website.

CCS v12.x: <https://www.ti.com/tool/download/CCSTUDIO>

After installing CCS, the next step is to import one of the template projects included as part of the TI C2000 Target Support Package. First, locate the projects/28xx.zip archives. This will be located in the TI C2000 Target Support Package directory that you have downloaded and installed from the web page [https://www.plexim.com/download/tsp\\_c2000](https://www.plexim.com/download/tsp_c2000).

Next, open CCS and click on the **Project** drop-down menu and then select **Import CCS Projects...** Then choose **Select archive file** and **Browse...** the zip archive in the projects folder that corresponds to the desired target. Select the discovered project and click on **Finish**. You will notice a new project created in your CCS workspace.

Then, in the **Project Explorer** tab of CCS, from the context menu of your project, add a new **Target Configuration File** or ccxml file for your target. Modify any required settings and test the connection with your MCU.

Next, re-open the context menu of your project and navigate to the **Properties + General** window, and make sure that the selected **Compiler version** matches the version recommended in the section “Requirements” (on page 3). If not, locate and install the recommended compiler version from the **Help** drop-down menu, under **Install Code Generation Compiler Tools... + TI Compiler Updates**.

Return to the PLECS application, navigate to the **Coder + Coder Options...** window and select the **Target** tab. Ensure the **Generate code into CCS project** option is selected as the **Build type**. Enter the location of the `${workspace_loc}/dev_28xx/cg/` folder from the CCS project into the **CCS project directory** field and click **Build**. Note that `{workspace_loc}` refers to the location of the imported project in the CCS workspace. You will notice several new files created in the `${workspace_loc}/dev_28xx/cg/` directory. Then, proceed to build and debug your project as you would a normal CCS project. The project will not compile without first generating code from PLECS.

Note that it is necessary to manually delete the contents of the `${workspace_loc}/dev_28xx/cg/` folder when generating code for a new subsystem of a different name, as the CCS builder will build all files in this folder, including old files.

## Start the External Mode

Once the generated code is running on the embedded target, the user can enter the External Mode to update Scopes in the PLECS application with real-time waveforms and change certain simulation parameters.

External mode can be configured to run over JTAG or Serial. This choice must be configured from the **Coder + Coder options... + Target + External Mode** window prior to building the project.

To establish a communication link over JTAG with your target, follow the instructions provided below:

- Open the **Coder options... + External Mode** tab and then select the  icon next to the **Target device** field.
- Select **Serial over GDB**, configure the device name to **127.0.0.1** and then click the **OK** button to proceed.
- Click the **Connect** button and if the connection is successful you will see the trigger controls activate.

To establish a communication link over Serial with your target, first configure the proper Rx/Tx GPIO from the **Coder + Coder options...+Target + External Mode** window. Then, **Scan** for the appropriate **Target device** and proceed to **Connect** to the target as described in the instructions above.

Note that the XDS interface typically has two serial interface channels. One interface is for debugging and the other is for auxiliary communication including UART. If the External Mode connection to the device is unsuccessful, it is possible the debug channel was selected instead of the auxiliary communication channel.

Set the **Number of samples** parameter to 200 and click on the **Start autotriggering** button. You will now see real-time data from the MCU in the PLECS Scopes. You can synchronize the data capture to a specific trigger event. To do so, change the **Trigger channel** selection from **Off** to the desired signal. The Scope will now show a small square indicating the trigger level and delay. If the level or delay are outside the current axes limits, a small triangle will be shown instead. Drag the trigger icon to change the trigger level; drag it with the left mouse-button pressed to change the trigger delay. Both parameters can also be set in the External Mode dialog.

---

**Note** While a trigger channel is active, the Scope signals are only updated when a trigger event is detected.

---

While the PLECS model is connected via the External Mode, the model is locked against modifications. To disconnect from the MCU and other External Mode connections, click on the **Disconnect** button or close the Coder Options dialog.

## Troubleshooting Guide

If you're unable to connect to the External Mode, see the suggestions below:

- 1 If you're using the Windows operating system, open the **Device Manager** and verify that the "Load VCP" port of the "XDS100 Class Auxiliary Port" under "Texas Instruments Debug Probes" is enabled (unplug the MCU from the computer and replug if necessary). If configured correctly, the appropriate auxiliary port should show up under "Ports", as shown in Figure 1.2.

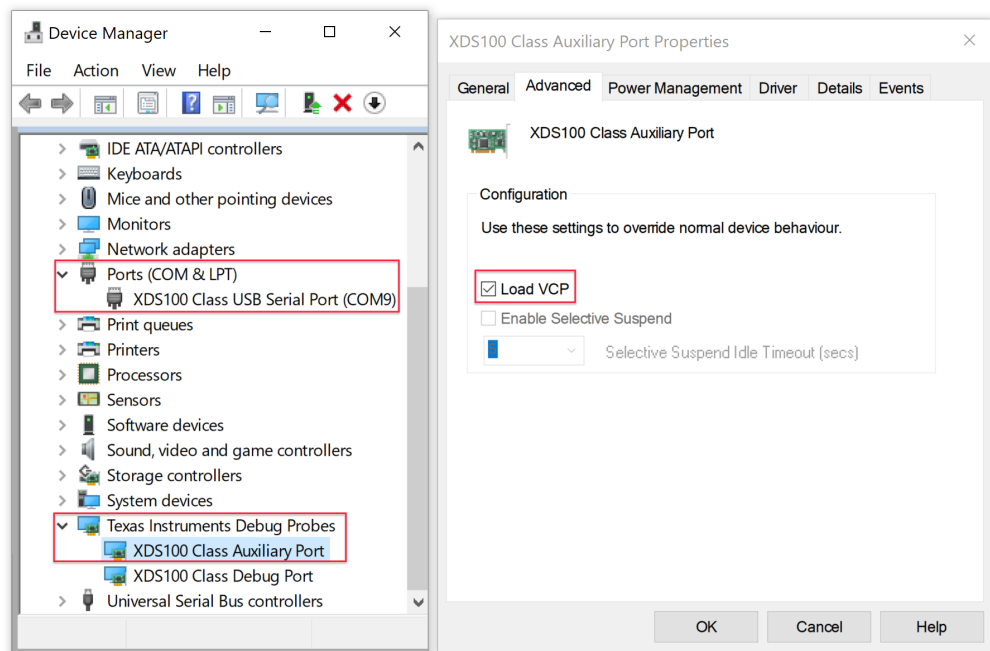

**Figure 1.2: Configuring Load VCP**

- 2 Verify that the jumpers are installed in the correct position. For information on the appropriate jumper settings, refer to the section "Tips for Program-

ming C2000 Development Kits” (on page 11), and to the data sheet of the MCU.

- 3 If there is insufficient time to execute the generated code, then the processor will halt and you won't be able to connect to the External Mode. In such a scenario, first, test that the External Mode works with a very simple model (e.g., toggle a GPIO) to ensure the problem is not due to a hardware or driver configuration. If the connection issue persists with a specific model, then potential solutions are:
  - Reduce the complexity of the model, for example by reducing the number of scopes or optimizing computationally intensive calculations.
  - Decrease the **Target buffer size** parameter under **Target +External Mode**.
  - Increasing the discretization step size.

## Tips for Programming C2000 Development Kits

TI offers development kits with standardized form factors to facilitate the development and testing of C2000 MCUs. Each TI C2000 development kit uses jumpers, DIP switches, or both jumpers and DIP switches to configure the target device's power isolation, communication isolation, and boot mode settings. The following settings are the recommended basic configuration to program the MCU via the default programming interface, boot from flash, and connect via the External Mode for supported devices. Users are responsible for ensuring the recommended settings are appropriate for their exact application and isolation requirements. Refer to the device documentation for more specific guidance on advanced configurations, such as the use of an external debug probe.

The documentation below includes other device specific guidance and recommendations to interface with the PLECS RT Box, where appropriate.

### External mode GPIO pins

The serial communication interface GPIO used for the External Mode will differ for between C2000 targets. The user must set the appropriate GPIO pin pair. The External Mode GPIO are configured in the **Target + External Mode** tab of the **Coder Options** window.

The table below summarizes the standard configuration for the TI development kits. In some cases the GPIO pair is altered by the jumper and switch positions on the LaunchPad or ControlCard device and should be changed accordingly.

### External mode GPIO pins

Development Kit(s)	GPIO[Rx,Tx]
LAUNCHXL-F280039 LaunchPad TMDSNCD280039C ControlCard	[28, 29]
LAUNCHXL-F280049 LaunchPad TMDSNCD280049C ControlCard	[28, 29]
LAUNCHXL-F28069 LaunchPad TMDSNCD28069 ControlCard TMDSNCD28069ISO ControlCard	[28, 29]
TMDSNCD28335 ControlCard	[28, 29]
LAUNCHXL-F28377S LaunchPad	[85, 84]
LAUNCHXL-F28379D LaunchPad	[43, 42]
TMDSNCD28379D ControlCard	[28, 29]
TMDSNCD28388D ControlCard	[28, 29]
LAUNCHXL-F28P65x LaunchPad	[43, 42]
TMDSNCD28P65X ControlCard	[28, 29]
LAUNCHXL-F28P55x LaunchPad TMDSNCD28P55X ControlCard	[28, 29]
F29H85X-SOM-EVM	[43, 42]

## TI28003x

### LAUNCHXL-F280039 LaunchPad

JP1 and JP2 configure the board power isolation. These jumper positions should be set based on the required isolation settings. J101 routes serial signals to the debugger. All J101 jumpers must be closed for serial communication.

The LAUNCHXL-F280039 can be configured with multiple functions set to the same header pins by adjusting the DIP switch positions. The basic recommended switch positions are shown below. Refer to the LaunchPad User's Guide for other possible configurations.

Note the "On" position corresponds to logic 1. Both S2 and S3 switches should be oriented towards the MCU chip.

#### **LAUNCHXL-F280039 Boot Mode DIP Switch Settings**

<b>Switch</b>	<b>Position</b>	<b>Purpose</b>
S2-1	Off	Route GPIO 28 and 29 to virtual COM port
S2-2	Off	Route GPIO 28 and 29 to virtual COM port
S3-1	On	GPIO 24 boot from flash
S3-2	On	GPIO 32 boot from flash

Note on the LAUNCHXL-F280039 the XDS110 Debug Probe is only wired to support 2-pin cJTAG mode. This should also be reflected in the ccxml target configuration file if manually generated.

#### **TMDSCNCD280039C ControlCard**

The 280039 ControlCard hardware should have the following DIP switch positions. S2 configures the boot settings for flash and S1:A configures emulation and UART communication. The "On" position for S1:A indicates the switch is positioned towards the left of the board. The "On" position for S2 indicates the switch is positioned at the top of the board.

GPIO 28 and 29 [Rx,Tx] are used for the External Mode interface.

**TMDSCNCD280039C ControlCard Key DIP Switch Settings**

Switch	Position	Purpose
S2-1	On	GPIO 24 boot from flash
S2-2	On	GPIO 32 boot from flash
S1:A-1	On	TRSTn tied to XDS110 for USB debugger connection
S1:A-2	On	Configure USB/UART on GPIO 28 and 29

**TI28004x****LAUNCHXL-F280049 LaunchPad**

JP1 through JP9 configure the board power isolation. These jumper positions should be set based on the required isolation settings. The LAUNCHXL-F280049 can be configured with multiple functions set to the same header pins by adjusting the DIP switch positions. The basic recommended switch positions are shown below. Refer to the LaunchPad User's Guide for other possible configurations.

GPIO 28 and 29 or GPIO 35 and 37 [Rx,Tx] can be used for the External Mode interface. The switch settings in the table below configure the device to use GPIO 28 and 29.

Note on the LAUNCHXL-F280049 the XDS110 Debug Probe is only wired to support 2-pin cJTAG mode. This should also be reflected in the ccxml target configuration file.

**LAUNCHXL-F280049 Key Jumper Settings**

Jumper	Position	Purpose
J101-RXD	Closed	Serial receive isolation
J101-TXD	Closed	Serial transmit isolation
J101-TMS	Closed	JTAG test mode select isolation

**LAUNCHXL-F280049 Key Jumper Settings (contd.)**

<b>Jumper</b>	<b>Position</b>	<b>Purpose</b>
J101-TCK	Closed	JTAG test clock isolation

Note that S2 is placed upside-down so the off position corresponds to logic 1 and the on position corresponds to logic 0. Both S2 switches should be oriented towards the MCU chip. S6 should be oriented towards the MCU chip and S8 away from the MCU.

**LAUNCHXL-F280049 Boot Mode DIP Switch Settings**

<b>Switch</b>	<b>Position</b>	<b>Purpose</b>
S2-1	Off	GPIO 32 boot from flash
S2-2	Off	GPIO 24 boot from flash
S6	Off	Route GPIO 28 and 29 to virtual COM port
S8	Off	Select GPIO 28 and 29 as serial pins

**TMDSCNCD280049C ControlCard**

The 280049 ControlCard hardware should have the following DIP switch positions. S1 configures the boot settings for flash and S1:A configures emulation and UART communication. The “Up” position for S1:A indicates the switch is positioned towards the top of the board. This corresponds to the “On” position, of the switch label. S1 is rotated 180 degrees, and so the “Up” position is towards the top of the board but opposite the “On” label of the switch.

GPIO 28 and 29 [Rx,Tx] are used for the External Mode interface.

### TMDSCNCD280049C ControlCard Key DIP Switch Settings

Switch	Position	Purpose
S1-1	Up	GPIO 24 boot from flash
S1-2	Up	GPIO 32 boot from flash
S1:A-1	Up	TRSTn tied to XDS100v2 for USB debugger connection
S1:A-2	Up	Configure USB/UART on GPIO 28 and 29

## TI2806x

### TI28069 ADC configuration

The TI28069 MCU has two ADC's, ADCINAx and ADCINBx. The ADC units are structured with a common results register. Therefore, when addressing ADCINBx channels, the **ADC unit** setting should be "ADC A" and the channel offset by a factor of 8. For example, ADCINB1 should be entered with an **ADC unit** value of "ADC A" and an **Analog input channel(s)** value of 9.

### LAUNCHXL-F28069 LaunchPad

JP1 through JP5 configure the board power isolation. These jumper positions should be set based on the required isolation settings. JP6 and JP7 configure the serial communication interface to use GPIO 28 and 29 as the Rx and Tx signals.

The DIP switches configure the boot mode settings. S1-SW3 should be in the position pointing away from the MCU chip.

### LAUNCHXL-F28069 Key Jumper Settings

Jumper	Position	Purpose
JP6	Open	Configure USB/UART on GPIO 28 and 29

**LAUNCHXL-F28069 Key Jumper Settings (contd.)**

<b>Jumper</b>	<b>Position</b>	<b>Purpose</b>
JP7	Closed	Configure USB/UART on GPIO 28 and 29

**LAUNCHXL-F28069 Key DIP Switch Settings**

<b>Switch</b>	<b>Position</b>	<b>Purpose</b>
S1-1	On	GPIO34 boot from flash
S1-2	On	GPIO37 / TDO boot from flash
S1-3	On	TRSTn tied to XDS100v2 for USB debugger connection

**TMDSNCD28069 ControlCard**

The TMDSNCD28069 ControlCard does not contain an onboard debugger and so an external debug probe is required. Due to the various external debug probe options, one must manually generate a \*.ccxml file via UniFlash or Code Composer Studio. The generated \*.ccxml must be referenced in the **Uniflash target configuration** field accessible in the **Coder options + Target + General** tab.

For external mode communication, the recommended approach is to use an FTDI to USB cable and SCI headers. Set the external mode to “Serial” and configure the Rx,Tx GPIO to 28 and 29.

The recommended boot switch configuration is to have both SW1 switches in the “On” position to boot from flash.

**TMDSNCD28069MISO ControlCard**

The isolated version of the 28069 ControlCard hardware has an onboard debugger. The following DIP switch positions are recommended. SW1 controls to boot settings and SW3 configures serial communication. GPIO 28 and 29 [Rx,Tx] are used for the External Mode interface.

### TMDSCNCD28069MISO ControlCard Key DIP Switch Settings

Switch	Position	Purpose
S1-1	On	GPIO 34 boot from Flash
S1-2	On	GPIO 37 / TDO boot from Flash
S3-1	On	TRSTn tied to XDS100v2 for USB debugger connection
S3-2	On	Configure USB/UART on GPIO 28 and 29

## TI2833x

The 28335 MCU development kits are limited to the TMDSCNCD28335 ControlCard formfactor.

### TMDSCNCD28335 ControlCard

The TMDSCNCD28335 ControlCard does not contain an onboard debugger and so an external debug probe is required. Due to the various external debug probe options, one must manually generate a \*.ccxml file via UniFlash or Code Composer Studio. The generated \*.ccxml must be referenced in the **Uniflash target configuration** field accessible in the **Coder options + Target + General** tab.

For external mode communication, the recommended approach is to use an FTDI to USB cable and SCI headers. Set the external mode to “Serial” and configure the Rx,Tx GPIO to 28 and 29.

The recommended boot switch configuration is to have SW1 in the “Off” position to enable serial communication. The “Off” position is oriented towards the bottom of the board. All SW2 positions should be in the “On” position to boot from flash.

## TI2837x

The F2837x processor family has single core and dual-core versions. When programming a dual-core chip, the PLECS Coder will only generate code for the

first core unless the second core is explicitly configured in the **Coder Options + Scheduling** tab. The TI2837xS target is only for single core devices while the TI2837x target supports both single and dual-core devices.

## LAUNCHXL-F2837x LaunchPad

TI offers two LaunchPad designs for the F2837x family of devices: the LAUNCHXL-F28379D and LAUNCHXL-F28377S. The recommended configuration for both devices are the same, with the exception of the External Mode settings noted below.

JP1 through JP5 configure the board power isolation. These jumper positions should be set based on the required isolation settings.

The DIP switches configure the boot mode settings. All S1 switches should be in the position pointing away from the MCU chip. For the DIP switch settings below, GPIO 43 and 42 [Rx,Tx] should be used for External Mode communication with the TI28379D MCU and GPIO 85 and 84 [Rx,Tx] should be used for the TI28377S MCU.

### LAUNCHXL-F2837x Boot Mode DIP Switch Settings

Switch	Position	Purpose
S1-1	On	GPIO84 boot from flash
S1-2	On	GPIO72 boot from flash
S1-3	On	TRSTn tied to XDS100v2

**Note** As per TI LAUNCHXL-F28379D Overview, in revision 1.1 of the TI 28379D launchpad, ADCINA2 is shorted to VREFHIB. It is recommended that users avoid using the ADCINA2 channel. This is fixed in revision 2.0.

## TMDSCNCD28379D ControlCard

The 28379D ControlCard hardware should have the following DIP switch positions. SW1 configures the boot settings for flash and A:SW1 configures emula-

tion and UART communication. For both switches, the “On” position is with the switch positioned towards the top of the ControlCard.

GPIO 28 and 29 [Rx,Tx] are used for the External Mode interface.

**TMDSCNCD28379D ControlCard Key DIP Switch Settings**

Switch	Position	Purpose
SW1-1	On	GPIO 72 boot from flash
SW1-2	On	GPIO 84 boot from flash
A:SW1-1	On	TRSTn tied to XDS100v2 for USB debugger connection
A:SW1-2	On	Configure USB/UART on GPIO 28 and 29

**TI2838x**

The development kits for the 2838x MCUs are limited to the ControlCard form factor.

**TMDSCNCD28388D ControlCard**

The 28388D ControlCard hardware should have the following DIP switch positions. S2 configures the boot settings for flash and S1:A configures emulation and UART communication. For both switches, the “On” position is with the switch positioned towards the right edge of the ControlCard. The “Off” position corresponds to logic 1 on GPIO 84 and 72.

GPIO 28 and 29 [Rx,Tx] are used for the External Mode interface.

**TMDSCNCD28379D ControlCard Key DIP Switch Settings**

Switch	Position	Purpose
S2-1	Off	GPIO 72 boot from flash
S2-2	Off	GPIO 84 boot from flash

**TMDSCNCD28379D ControlCard Key DIP Switch Settings (contd.)**

Switch	Position	Purpose
S1:A-1	On	TRSTn tied to XDS100v2 for USB debugger connection
S1:A-2	On	Configure USB/UART on GPIO 28 and 29

**TI28P55x****LAUNCHXL-F28P55X LaunchPad**

JP1, JP2, JP8, and J16 configure the board power isolation. These jumper positions should be set based on the required isolation settings. J101 routes serial signals to the debugger. All J101 jumpers must be closed for serial communication. Additionally, JP9 connects a termination resistor to the CAN header, and J15 offers an analog voltage reference pin that can be driven with an external voltage reference source. The LAUNCHXL-F28P55X also features several DIP switches that can be used to configure the boot settings, CAN routing, QEP routing, PGA routing, and the function of GPIOs 15, 24, 28, 29, 32, and 56. The basic recommended switch positions and jumper configurations are shown below. Refer to the LaunchPad User's Guide for other possible configurations.

Note on the LAUNCHXL-F28P55X the XDS110 Debug Probe is only wired to support 2-pin cJTAG mode. This should also be reflected in the ccxml target configuration file.

**LAUNCHXL-F28P55X Key Jumper Settings**

Jumper	Position	Purpose
JP1	Closed	USB Type-C 5V and GND isolation
JP8	Closed	BoosterPack 3.3V/5V isolation
JP9	Closed	CAN termination
J16	Open	Disable 3.3V to 5V boost

**LAUNCHXL-F28P55X Key Jumper Settings (contd.)**

<b>Jumper</b>	<b>Position</b>	<b>Purpose</b>
J101-RXD	Closed	Serial receive isolation
J101-TXD	Closed	Serial transmit isolation
J101-TMS	Closed	JTAG test mode select isolation
J101-TCK	Closed	JTAG test clock isolation
J101-TDO	Closed	JTAG test data output isolation
J101-TDI	Closed	JTAG test data input isolation

**LAUNCHXL-F28P55X DIP Switch Settings**

<b>Switch</b>	<b>Position</b>	<b>Purpose</b>
S2-SEL1	0	GPIO 28/29 routed to XDS COM port
S2-SEL2	0	GPIO 15/56 routed to BoosterPack headers
S3-GPIO24	1	Boot from Flash
S3-GPIO32	1	Boot from Flash
S4	Up (BP)/Down (XCVR)	Route GPIO 4/5 to Booster-Pack header J4 (Up) or to CAN transceiver J14 (Down)
S5-Q3	Up (BP)/Down (J13)	Route GPIO 25/26/30 to BoosterPack header J6 (Up) or to QEP header J13 (Down)
S6	1 (Left)	Route PGA 1/2/3 GPIOs to BoosterPack headers

## TMDSCNCD28P55X ControlCard

The 28P55X ControlCard hardware should have the following DIP switch positions. S1 configures the boot mode, S3 configures voltage referencing, and S4 configures emulation and UART communication. For S1, the “On” position is set upwards towards the top of the ControlCARD (just under LEDs D1 and D2). For S3, the “On” position is leftwards towards the USB insert side of the ControlCARD, and for S4 it is the opposite, rightwards away from the USB side of the ControlCARD.

GPIO 28 and 29 [Rx,Tx] are used for the External Mode interface.

### TMDSCNCD28P55X ControlCard Key DIP Switch Settings

Switch	Position	Purpose
S1-1	On	GPIO 24 boot from Flash
S1-2	On	GPIO 32 boot from Flash
S3	Off	Use internal voltage reference
S4-1	On	TRSTn tied to XDS110 for USB debugger connection
S4-2	On	Configure USB/UART on GPIO 28 and 29

## TI28P65x

### LAUNCHXL-F28P65X LaunchPad

JP1, JP8, J16, and J17 configure the board power isolation. These jumper positions should be set based on the required isolation settings. Additionally, JP9 connects a termination resistor to the CAN header, and J15 connects the analog voltage reference pin to the 3V reference generated by the LaunchPad board. The LAUNCHXL-F28P65X also features several DIP switches that can be used to configure the boot settings, CAN routing, QEP routing, and the function of GPIOs 38, 42, 43, and 55. The basic recommended switch positions and jumper configurations are shown below. Refer to the LaunchPad User’s Guide for other possible configurations.

**Note** The F28P65x LaunchPad comes by default with jumpers configured to use an onboard "external" 3.0V reference. For correct results ensure your jumper configuration matches the configuration set in the **Coder options... + Target + ADC** menu.

**LAUNCHXL-F28P65X Key Jumper Settings**

<b>Jumper</b>	<b>Position</b>	<b>Purpose</b>
JP1	Closed	USB Type-C 5V and GND isolation
JP8	Closed	BoosterPack 3.3V/5V isolation
JP9	Closed	CAN termination
J15	Closed	Use 3V external reference voltage
J16	Closed	Enable 5V to 3.3V LDO
J17	Open	Disable 3.3V to 5V boost

**LAUNCHXL-F28P65X DIP Switch Settings**

<b>Switch</b>	<b>Position</b>	<b>Purpose</b>
S2-SEL1	0	GPIO 42/43 routed to XDS COM port
S2-SEL2	0	GPIO 38/55 routed to BoosterPack headers
S3-GPIO72	1	Boot from Flash
S3-GPIO84	1	Boot from Flash

**LAUNCHXL-F28P65X DIP Switch Settings (contd.)**

<b>Switch</b>	<b>Position</b>	<b>Purpose</b>
S4	Up (BP)/Down (XCVR)	Route GPIO 4/5 to Booster-Pack header J4 (Up) or to CAN transceiver J14 (Down)
S5-QEP1	Up (BP)/Down (J12)	Route GPIO 20/21/23 to BoosterPack header J2 (Up) or to QEP header J12 (Down)
S5-QEP2	Up (BP)/Down (J13)	Route GPIO 24/79/103 to BoosterPack header J6 (Up) or to QEP header J13 (Down)

**TMDSCNCD28P65X ControlCard**

The 28P65X ControlCard hardware should have the following DIP switch positions. S1 configures emulation and UART communication. For S1, S5, and S6 the “On” position is with the switch positioned towards the EtherCAT connectors on the right edge of the ControlCard. For S3 the “On” position is with the switch positioned towards the upper edge of the ControlCard for a logical high at the GPIO pin.

---

**Note** The F28P65x ControlCard comes by default with DIP switches configured to use an onboard "external" 3.0V reference. For correct results ensure your DIP switch configuration matches the configuration set in the **Coder options... + Target + ADC** menu.

---

GPIO 28 and 29 [Rx,Tx] are used for the External Mode interface.

**TMDSCNCD28P65X ControlCard Key DIP Switch Settings**

Switch	Position	Purpose
S1-1	On	TRSTn tied to XDS110 for USB debugger connection
S1-2	On	Configure USB/UART on GPIO 28 and 29
S3-1	On	GPIO 72 boot from flash
S3-2	On	GPIO 84 boot from flash
S5-1	On	GPIO ADC-C configured to use external voltage reference
S5-2	On	GPIO ADC-B configured to use external voltage reference
S6-1	On	GPIO ADC-A configured to use external voltage reference
S6-2	On	GPIO External voltage reference set to onboard 3.0 V

**TI29H85x**

The F29H85X device supports multiple Flash bank modes that determine CPU access to Flash memory. New devices ship in mode 0, where all Flash is allocated to CPU1. To enable code execution on CPU1 and CPU3, the device must be reconfigured to Flash bank mode 2. This configuration can be performed using UniFlash through the **Settings & Utilities** section.

**F29H85X-SOM-EVM**

Refer to the F29H85X SOM-EVM documentation for DIP switch settings regarding the boot mode and analog voltage references. Note that this EVM has a single-ended 25 MHz external clock, which is not functional with earlier silicon versions. It is therefore recommended that the internal oscillator be used.

You may use the F29H85X-SOM-EVM in conjunction with the HSEC180 adapter board (HSEC180ADAPEVM) as a ControlCard equivalent.

## **TI C2000 Target Support and the PLECS RT Box**

Real-time simulation is a powerful tool to validate embedded control code, whether hand written or generated using embedded code generation techniques. The PLECS RT Box is the natural choice for real-time simulation since the offline simulation, real-time model, and embedded control code can all be derived from a common PLECS model.

Plexim offers a set of interface boards to facilitate the connection of LaunchPad and ControlCard development kits from TI. It is important to note that these interface boards route a digital output of the RT Box to the MCU reset pin via the RST jumper. If the jumper is closed then a low-level output from the RT Box will reset the MCU. Do not set this jumper unless you wish to use this feature, as it will interfere with programming the target processor. The RT Box provides board power to the LaunchPad device, and therefore the USB isolation jumpers should be removed when connected to the USB port.



# C2000 Target Support Architecture

## Overview

As a separately licensed feature, the PLECS Coder can generate C code from a simulation model to facilitate embedded code generation. Plexim provides and maintains target support packages for specific processor families. A target support package enables the PLECS Coder to generate code that is specific to a particular hardware target such as the TI C2000 family of MCUs or the PLECS RT Box. With the PLECS Coder and a target support package embedded control code can be generated, compiled, and uploaded to the target device directly from the PLECS environment with minimal effort. Furthermore, the embedded control logic can be tested extensively inside the PLECS simulation environment prior to real-time deployment.

## The Embedded Code Generation Workflow

The embedded workflow is designed for you to easily transition from a PLECS model to an embedded code generation project without having to build and maintain separate models. A typical embedded code generation workflow consists of the following steps:

- 1 Design and simulate a controller and plant in PLECS. The controller represents the application that will run on the embedded target. The plant represents the hardware connected to the embedded target including the power stage and other physical systems.

- 2** Add components from the target support library to configure the embedded peripheral devices. Place the controller and peripheral models into a subsystem representing the embedded target.
- 3** Run an offline simulation. All peripheral components in the target support library have behavioral offline models to facilitate the transition from simulation to real-time deployment.
- 4** Select a discretization step size and nominal control task execution frequency. When generating C code, the PLECS Coder will use the discretization step size to automatically transform all continuous states in the controller to the discrete state-space domain using the Forward Euler method. The control task execution frequency is based on the discretization step size and specifies the nominal execution rate of the digital control loop.
- 5** Build the embedded project and flash the MCU using PLECS or Code Composer Studio.
- 6** Connect to the MCU using the External Mode to test the embedded control code executing on the embedded target.

## Control Task Execution

Embedded applications for power electronics typically sense signals from the power converter, process the input signals using digital control laws, and output signals to actuation devices. The TI C2000 Target Support Package library includes components to model and program the MCU peripherals for sensing and actuation. The control laws are implemented using standard PLECS library components.

Time synchronization of signal measurement via the analog-to-digital converter (ADC), control logic execution, and actuation via PWM outputs is critical in the digital power electronic control loop. The TI C2000 Target Support Package provides the flexibility to configure the ADC and control loop interrupts through the ADC trigger and task trigger signals.

ADC triggers configure the ADC start-of-conversion. The ADC start-of-conversion is driven by an interrupt from either a PWM carrier or the CPU Timer. All ADC channels associated with the ADC unit are converted sequentially when the ADC trigger is activated. The order of conversion is based on the order of the analog input channel vector.

Task triggers are generated by the ADC end-of-conversion signal, PWM counter underflow and overflow events, or the Timer block. The task trigger that connects to the Control Task Trigger component will periodically trigger one execution of the digital control loop at the nominal base sample rate.

---

**Note** In the following sections, unless specified otherwise, *control task* and *base task* can be considered synonymous.

---

## Control Task Accuracy and PWM Frequency Tolerance

The MCU system clock frequency, SYSCLK, fundamentally limits the time accuracy of the embedded target. SYSCLK is defined in the **Target + General** tab of the **Coder + Coder Options** window. The CPU Timer and PWM carrier generation clocks are derived from an integer number of counts of SYSCLK. Therefore the time accuracy of task triggers and PWM carriers are also limited.

Consider the case where there is a desired PWM carrier frequency of 150 kHz and the SYSCLK is set to 100 MHz. The closest achievable PWM carrier frequency is 150.15 kHz. Note that if the SYSCLK setting was changed to 90 MHz, then the target PWM frequency of 150 kHz could be achieved exactly.

In cases where the PWM carrier frequency or ADC and task trigger periods cannot be achieved exactly, the default behavior is to generate an error message displaying the desired frequency or step size and the closest achievable value. Adjusting the **Frequency tolerance** parameter overrides this behavior and configures the PLECS Coder to automatically select the closest achievable frequency. The **Frequency tolerance** can be configured in the mask parameters of the Timer, PWM, and PWM (Variable) target support library blocks.

The discretization step size configured in the **Scheduling** tab of the **Coder + Coder Options** will also generate an error if the exact step size cannot be achieved. This impacts the nominal period of the task trigger and introduces a numerical inaccuracy since C code derived from the model executes at a different rate than was assumed during model discretization. The **Frequency tolerance** parameter relating to model and control task discretization can be adjusted in the **General** tab of the **Coder + Coder Options + Target** window.

### Explicit and Implicit Trigger Definitions

The interrupt sequence of the embedded application can be defined explicitly by connecting trigger signals, or implicitly where the interrupt sequence is automatically determined based on the components included in the schematic. Implicitly defined control loops will not have a Control Task Trigger component included in the schematic and all ADC trigger sources must be automatically determined. Several possible explicit and implicit trigger sequences are discussed below.

---

**Note** Explicitly defined trigger systems require that the Control Task Trigger's nominal base sample time parameter agrees with period of the task trigger input signal.

---

## Control task triggered by CPU Timer

In a basic project without an ADC or PWM component from the target support library, the task trigger must be generated by the CPU Timer. The schematic below shows a simple application where a GPIO is toggled at a fixed rate.

The explicit representation of the control task execution includes a Timer component that generates the input signal for the Control Task Trigger. The nominal base sample time of the Control Task Trigger must agree with the CPU Timer task frequency. In the implicit representation the PLECS Coder will configure the CPU Timer and Control Task Trigger automatically based on the **Discretization step size** parameter (in single-tasking mode) or base task sample rate (in multi-tasking mode) set in the **Coder + Coder Options + Scheduling** menu.

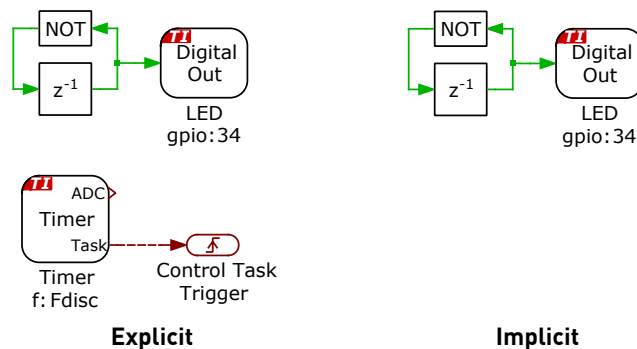

**Figure 2.1: Basic model with control task triggered by CPU Timer**

### Control task triggered by PWM

Control task execution can be synchronized with the PWM carrier underflow and overflow events. The task trigger is configured in the **Events** tab of the PWM component.

In the explicit representation the PWM task trigger output is connected to the Control Task Trigger component, such that execution of the digital control loop will begin when the PWM carrier reaches an underflow (minimum value) or overflow (maximum value). If the schematic does not include a Control Task Trigger or an ADC component, then the PLECS Coder will implicitly select the most appropriate source for the task trigger. First, the PWM generator that can achieve the control task frequency with the highest precision is chosen, starting from the lowest PWM number. If the control task frequency cannot be achieved exactly using a PWM carrier, then the implicit trigger logic will determine if more accurate task execution can be achieved with the CPU Timer. The most accurate source for the control task interrupt is then selected.

The task trigger will default to triggering on underflow and overflow when the task trigger is set to disabled in the PWM **Events** tab and the trigger is implicitly defined.

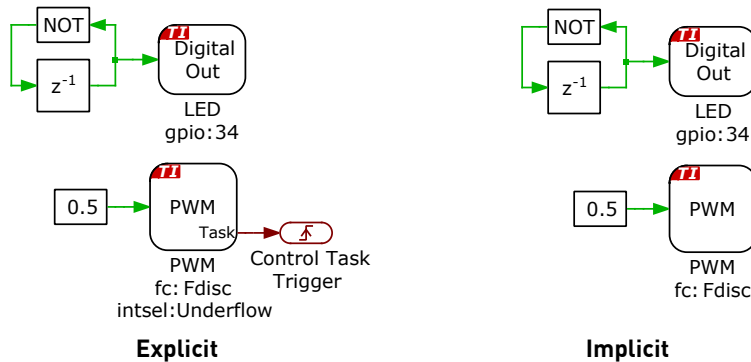
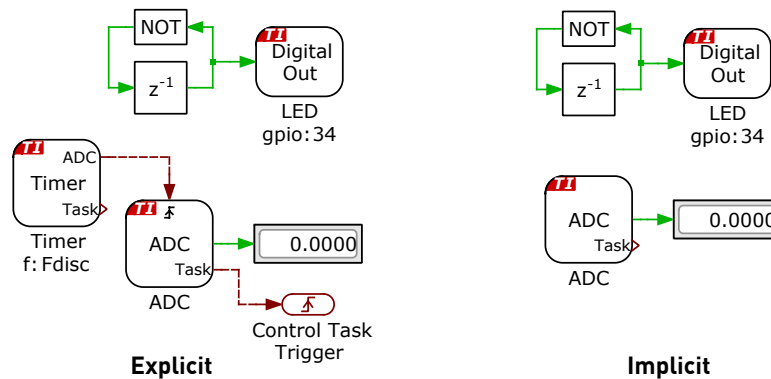

**Figure 2.2: Basic model with control task triggered by PWM**

## Control task triggered by CPU Timer via ADC

If the schematic includes an ADC but no PWM generators, then the ADC start-of-conversion must be triggered by the CPU Timer. In this case, the control task can be triggered by the ADC end-of-conversion or the CPU Timer. When the ADC end-of-conversion is the source of the Control Task Trigger input, as shown in Figure 2.3, then the control loop interrupt will occur after all ADC results registers are updated with the latest measurement values.

The implicit implementation automatically configures the CPU Timer to periodically trigger the ADC start-of-conversion. The ADC trigger period is set by the **Discretization step size** parameter (in single-tasking mode) or base task sample rate (in multi-tasking mode) set in the **Coder + Coder Options + Scheduling** menu. The ADC unit with the greatest number of channels will trigger the control task.



**Figure 2.3: Basic model with control task triggered by ADC**

### Control task triggered by PWM via ADC

Figure 2.4 shows the explicit and implicit implementations of the control task being triggered by the ADC via the PWM. The sequence of events begins when the PWM carrier reaches an underflow or overflow triggering the start-of-conversion signal for the first ADC channel. The ADC channels are sampled and updated sequentially until the result register of the final ADC channel is updated. Once all ADC results are available, the ADC end-of-conversion interrupt triggers the control task. This arrangement synchronizes the ADC start-of-conversion with the PWM actuation and ensures the ADC results registers are updated prior to executing the control loop.

When both ADC and PWM components are included in any schematic, the PLECS Coder will implicitly select the PWM generator with the highest control task accuracy as the ADC trigger. If the PWM generators cannot trigger the ADC at the exact target frequency, then the CPU Timer will be used if it is more accurate. The control task will always be triggered by the ADC end-of-conversion signal.

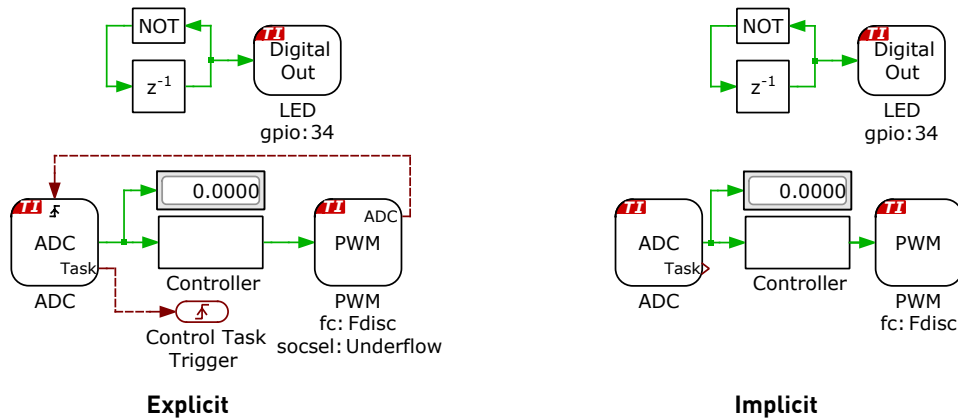
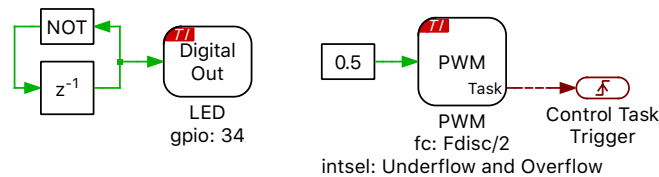

Figure 2.4: Basic model with control task triggered by PWM via ADC

## Advanced explicit configurations

The control task interrupt can execute at integer multiples of the PWM carrier frequency, and for a symmetric carrier the control task can be triggered at twice the PWM carrier frequency.

Figure 2.5 shows a case where the discretization frequency is  $F_{disc}$ , the symmetric PWM carrier period is  $T_{sw} = 2/F_{disc}$  Hz, and the Control Task Trigger interrupt period is  $T_{CtrlTask} = 1/F_{disc}$ . The control task is triggered twice per PWM period. Figure 2.6 shows the corresponding PWM carrier, task trigger, and PWM outputs.



**Figure 2.5: PWM frequency set to half the control task frequency**

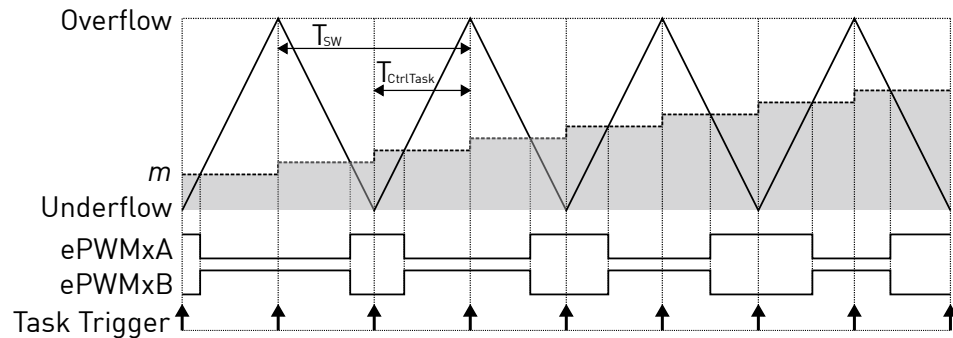

**Figure 2.6: PWM carrier and task interrupts for PWM frequency set to half the control task frequency**

Figure 2.7 shows a case where the discretization frequency is  $F_{disc}$ , the symmetric PWM carrier period is  $T_{sw} = 1/(2 \cdot F_{disc})$  Hz, and the Control Task Trigger interrupt is generated at  $T_{CtrlTask} = 1/F_{disc}$ . Figure 2.8 shows the corresponding PWM carrier, task trigger, and PWM outputs.

The C2000 target support package by default will only update the ePWM duty cycle register on PWM underflow and overflow events to prevent data corruption. In Figure 2.8 note the delay between the task trigger and the instant when the duty cycle,  $m$ , is updated in the ePWM module. The task trigger initiates the control task computation, but the modulation index is updated on the next overflow or underflow event after the entire control task has been completed. When the control task is triggered by the ADC end-of-conversion, then the modulation index will update on the next overflow or underflow event after all ADC channels are converted and the control task is completed.

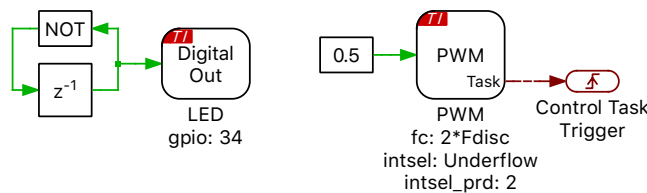

**Figure 2.7: Schematic of PWM frequency set to twice the control task frequency**

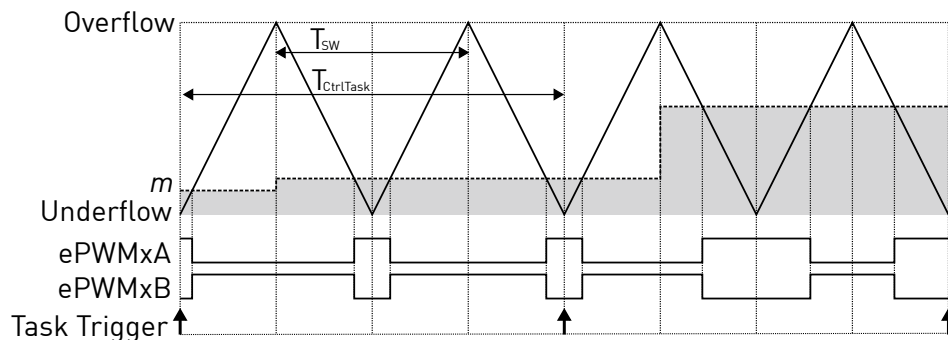

**Figure 2.8: PWM carrier and task interrupts for PWM frequency set to twice the control task frequency**

Each ADC can receive independent start-of-conversion triggers from different PWM generators for phase-shifted sampling. Figure 2.9 shows the case where the ADC1 component is triggered on the carrier overflow and ADC2 is triggered on carrier underflow from two different PWM modules with a common carrier frequency. After all channels associated with ADC2 are converted the control

task is executed with updated measurements from ADC1 and ADC2. On the next carrier overflow the ePWM duty cycle register is updated.

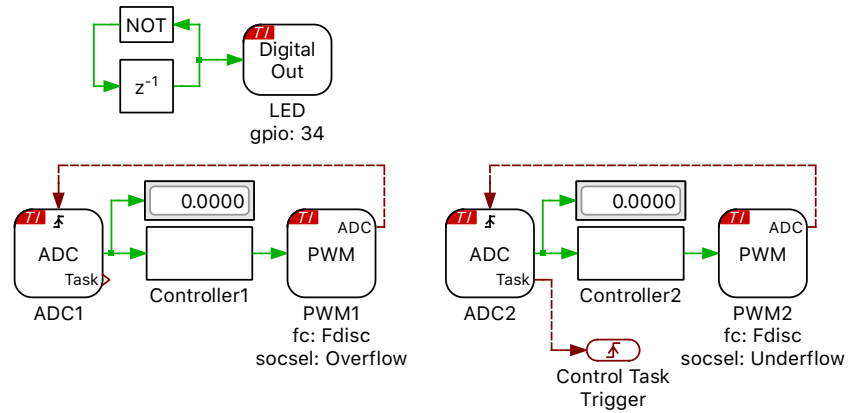

**Figure 2.9: Explicit phase-shifted ADC sampling**

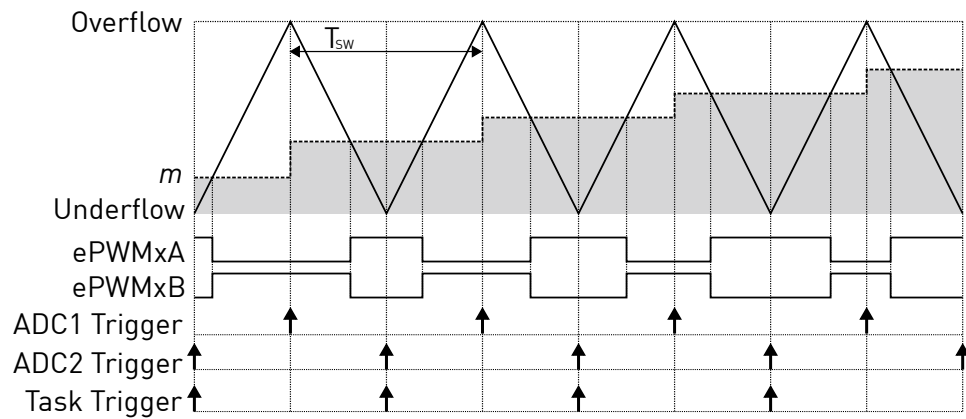

**Figure 2.10: PWM carrier and interrupts for phase-shifted ADC sampling**

## Multi-Tasking and Dual-Core Execution

The PLECS Coder and the TI C2000 Target Support Package supports multi-tasking code generation and code generation for supported dual-core MCUs.

By default, the PLECS Coder will generate all control code into a single base task executing on a single processor core. Configuring multi-tasking and dual-core operation, as described in the following section, can unlock processing power for applications that require regulating multiple system outputs with dynamics on a range of time-scales.

### Multi-tasking Operation

The embedded application framework includes a rate monotonic scheduler to allow precise and efficient execution of the digital control loops.

With multi-tasking code generation users can define tasks that execute at a slower rate and with a lower priority than the base task. The scheduler determines which task should execute at a given instant. When scheduled, higher priority tasks can suspend lower priority tasks in the middle of execution. Assigning computations to lower priority tasks preserves processor resources for higher priority tasks in the application.

The base task has the highest priority. Up to 15 slower lower-priority tasks, executed at different rates, can be specified. Lower-priority tasks must have a sample time that is an integer multiple of the base sample time. The task sample time order defines the task priority. A lowest-priority background task also exists to handle non-time critical tasks. Figure 2.11 shows a configuration with a base task, two additional tasks, and a background task. “Additional task 1” occurs every two base task periods, and “Additional task 2” occurs every four base task periods.

With every control task trigger interrupt issued by the CPU Timer, PWM, or ADC end-of-conversion, any lower priority tasks are interrupted and the base task is executed. This ensures that the control task has the highest priority. In addition, the lower priority tasks are periodically triggered and executed when no higher priority tasks are active or pending.

If the base task is still executing when a second control task interrupt is received, then the processor will halt and an assertion will be generated. Similar behavior occurs if a low priority task does not complete by the time it is scheduled to execute again. Assertions can be monitored using CCS debug tools.

Once the base and additional tasks have completed, the system continues with the background task where lowest priority operations are processed.

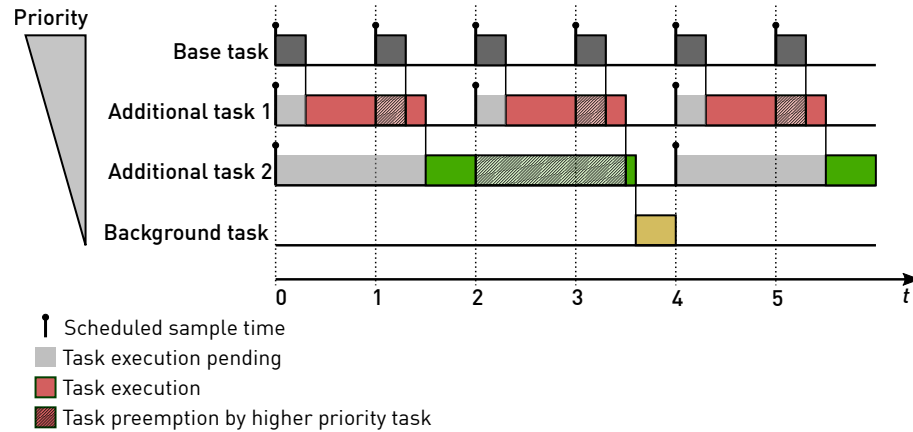
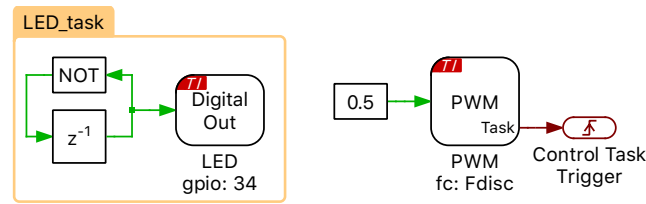

**Figure 2.11: Nested control tasks**

## Multi-tasking mode configuration

Multi-tasking code generation is configured by setting the **Tasking mode** to multi-tasking in the **Scheduling** tab of the **Coder + Coder options...** menu. New tasks and their sample time are assigned in the **Task configuration** table. The base sample time is the shortest **Sample time** of the assigned tasks. The **Sample time** setting for lower priority tasks must be an integer multiple of the base sample time. The Task component in the PLECS library assigns blocks in the simulation model to the defined tasks. For further information on task scheduling, refer to the “Code Generation” section in the PLECS User Manual.

An example of an additional LED task, along with a base PWM task is shown in figure 2.12.



**Figure 2.12: Example of an additional LED task along with a base PWM task**

### Task transitions in multi-tasking mode

Blocks in one task may receive input signals from other tasks with a higher or lower priority than the receiving tasks. The PLECS Coder ensures data transfer between tasks occurs safely by inserting code equivalent to a zero order hold, a delay, or a double buffer with semaphore. The task transition behavior depends on the relative execution rates of the sending and receiving tasks. By default, the PLECS Coder prioritizes deterministic data transfer times over the lowest possible latency. Refer to the “Task Transitions in Multi-Tasking Mode” in the “Code Generation” section of the PLECS User Manual for implementation details.

### Dual-core Operation

The dual-core TI C2000 MCUs contain two independent processing cores, the processors execute independently so time-critical tasks execute in parallel. The two CPU cores have access to the same set of underlying peripherals and a shared memory space for inter-processor communication.

As the CPU cores are independent of each other, each CPU core executes its own rate monotonic scheduler. Each CPU core requires a task trigger, whether implicit or explicit, to configure the base task interrupt the CPU. If one core encounters a run-time error such as a CPU overflow, the second core will continue to execute. The sample times for all tasks on a given CPU core must be an integer multiple of the core’s base task sample time. However, the two CPU cores do not need to have the same base task sample time.

### Dual-core mode configuration

Dual-core targets are configured using a single subsystem with code generation enabled. The single subsystem approach facilitates offline simulation of the en-

tire control system.

For dual-core execution the **Tasking mode** parameter, configured in the **Scheduling** tab of the **Coder + Coder options...** dialog, must be set to multi-tasking. In addition to a task name and sample time, as described previously for multi-tasking mode configuration, each task also is assigned a CPU resource. The Task component in the PLECS library assigns blocks in the simulation model to the defined tasks, and therefore to the CPU associated with the task.

The Task component also assigns ownership of peripheral blocks such as the ADC, PWM, and Powerstage Protection to the associated CPU core. The Powerstage Protection block only disables PWM blocks on the same core.

---

**Note** To enable dual-core operation on F29H85x devices, program the device to Flash bank mode 2 using UniFlash through the **Settings & Utilities** section.

---

### Task transitions in dual-core mode

For task transitions between different cores, the write operation in the source task can occur simultaneously with the read operation in the destination task. The inter-processor communication protocol uses a double buffer with two semaphores to guarantee that simultaneous read and write operations never access the same buffer.

The task execution of the two CPUs asynchronous and therefore data transfer times are non-deterministic.

## The Code Generation Project

This section provides additional technical background on the software architecture of the embedded code generation project included with the TI C2000 Target Support Package. A Code Composer Studio (CCS) project is included for each supported target chip in the `dev/28xx` folder of the target support package. When building the project from directly from the PLECS application, the files in `c2000/TI28xx` folder of the target support package are used.

### Static and dynamic code

The embedded code generation project consists of dynamic and static code. Dynamic code is generated by the PLECS Coder and is overwritten each time the **Build** button is clicked in the **Coder + Coder options...** window. Static code is provided with the target support package and should not be modified. The PLECS Coder also generates additional dynamic configuration files that are used by the embedded application.

When the **Build type** option is set to **Generate code into CCS project** then all generated dynamic code must be placed into the `{workspace_loc}/dev/28xx/cg/` of the imported CCS project. If the **Build type** parameter is set to **Build and program** then by default all generated code is included in a new output directory in the same folder as the saved PLECS model.

### Embedded project architecture

Figure 2.13 shows the architecture of the embedded project included with the TI C2000 Target Support Package. At the top of the software stack is an application layer consisting of the main application and the base and additional tasks. Next, there is a minimal real-time operating system that provides a rate monotonic scheduler for the nested control tasks, as previously described, and a processor-in-the-loop (PIL) framework that acts as middleware for External Mode communication with the PLECS application on the user PC. The hardware abstraction layer (HAL) provides a hardware agnostic interface between the application and chip specific configuration settings. This ensures code portability between different processor platforms. The hardware specific function calls utilize the TI C2000 drivers to configure the MCU and key peripherals. At the bottom of the stack is the embedded hardware which includes the MCU, peripheral devices, and other onboard accessories.

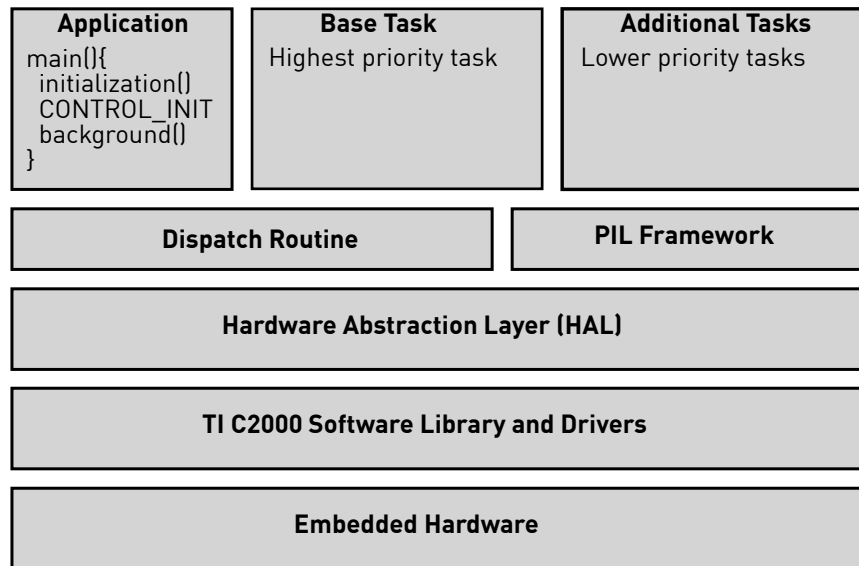

**Figure 2.13: Embedded project architecture**



# TI C2000 Coder Options

The **Target** page contains code generation options which are specific to the TI C2000 Target Support Package.

## General

**Chip** Selects the target device chip.

**System clock frequency (SYSCLK)** Specifies the system clock frequency in megahertz (MHz).

**Use internal oscillator** Selects the on-chip oscillator as the clock source. The clock frequency is automatically specified based on the target device.

**External clock frequency** Specifies the frequency in megahertz (MHz) of the external clock source when the internal oscillator is not used.

**Step size tolerance** The desired control task frequency may not be achievable based on the system clock frequency and the nominal discretization time step. This setting configures the Coder to either **Enforce exact** value by generating an error when the exact control task frequency is unachievable or to automatically **Round to closest achievable** value.

**Step size tolerance band [%]** Specifies the acceptable percent deviation in frequency from the specified value when the exact control task frequency is unachievable.

**Build type** This setting specifies the action of the **Build** button. **Generate code into CCS project** will generate code into the specified Code Composer Studio (CCS) project. CCS must then be used to build the project and flash the MCU. The **Build and program** option will automatically build and flash the target device from within PLECS using the provided **Build configuration** and **Board** type.

**CCS project directory** Specifies the target folder for code generation. The code must be generated into a pre-configured CCS project. When using the CCS project templates provided with the C2000 target support package, code must be generated into the `{workspace_loc}/dev_28xx/cg` folder where `{workspace_loc}` refers to the location of the imported project in the CCS workspace.

**Build configuration** Provides an option to either Run from Flash or Run from RAM.

**Board** This setting allows selecting preconfigured UniFlash target configurations. If using either a TI LaunchPad or a TI controlCARD, LaunchPad or ControlCard should be selected. If using a Custom board instead, a custom UniFlash target configuration file must be provided.

**UniFlash target configuration** Defines the `.ccxml` target configuration file for custom boards. The target configuration file can be generated from TI UniFlash or from CCS.

## PGA

This tab allows for the configuration of the Programmable Gain Amplifiers that are present on 28004x devices. Each unit can be enabled and configured in terms of its gain and filter resistance.

## PWM

This tab provides an option to configure an alternate set of GPIO resources for PWM modules. When a selection is not made, the PWM channel will use the default GPIO resources. This feature is available on all devices with the exception of 2806x and 2833x.

## Protections

Digital and analog inputs can be configured on this tab to generate trip events for the Powerstage Protection block. Note that in order for a protection input to have an effect it has to be explicitly activated in the Powerstage Protection (see page 80) block.

---

## Digital trips

Up to three trip zone digital input can be enabled and configured. Digital trips are active low inputs, i.e. a logical low input will activate the trip zone logic.

## Analog trips

For targets with CMPSS peripherals, up to 4 analog window comparators can be enabled and configured for generating trip signals for the Powerstage Protection block. Both ADC and PGA pins may be selected as protection inputs, as long as they have an internal connection to a CMPSS comparator module. The comparator is automatically determined by PLECS and an error message is issued in case no suitable comparator is found.

The user can configure both an upper and lower threshold. A trip signal is generated if the input falls below the lower threshold or exceeds the upper threshold. Note that it is allowable to set the lower threshold to 0.0 V, or the upper threshold to 3.3 V, thereby eliminate one of the trip regions. Each analog trip can be configured to emit one of three specific trip signals (labeled A, B, or C). A particular trip signal may be emitted by multiple analog trip inputs.

**Input type** Choose between ADC input or PGA input as protection inputs. This parameter is only shown for targets that feature PGA inputs.

**ADC unit** Selects the peripheral index for the ADC input when there are multiple ADC submodules.

**ADC input channel** Index of the analog input channel for a specific ADC submodule to be used as the protection input.

**PGA unit** Selects a Programmable Gain Amplifiers input (not available on all devices).

**Upper threshold voltage** Configures the upper threshold in volts (V). A value of 3.3 V is allowed to eliminate one of the trip regions.

**Lower threshold voltage** Configures the lower threshold in volts (V). A value of 0.0 V is allowed to eliminate one of the trip regions.

**Emit trip signal** Configures to emit one of three specific trip signals: A, B, or C.

## ADC

This tab allows selection of the **ADC Voltage Reference** being used. Available options may include internal and/or external references, depending on the selected Target. For example, a setting of Internal 3.3V will configure the target to use the 3.3V reference internal to the chip. If an External ADC reference is selected, enter the value in volts of the external voltage reference provided by the board to the chip. The default values are chosen to work on TI evaluation hardware.

## External Mode

These options are used to configure the External Mode communication with the target device.

**Enable External Mode** This setting adds code to the target device that enables the External Mode. Code size and memory consumption are increased when the External Mode is enabled.

**Target buffer size** Specifies how much target memory (16-bit words of RAM) should be allocated to buffering signals for the external mode. The number of words  $N_w$  required by the external mode can be calculated as follows:  $N_w = N_{signals} \cdot 2 \cdot (N_{samples} + 1)$ . If more samples are requested than what is supported by the memory allocation, PLECS will automatically truncate the scope traces to the maximal possible  $N_{samples}$  value. Note, however, that requesting more memory than what is available on the target will result in a build error. Recommended values for this setting are in the range of [500 . . . 2000].

**GPIO [Rx/Tx]** Specifies the GPIO pins used for the External Mode SCI connection. These GPIO pins cannot be used by other peripherals.

# TI C2000 Target Support Library Component Reference

This chapter lists the contents of the TI C2000 Target Support library in alphabetical order.

## ADC

**Purpose** Output the measured voltage of the ADC peripheral

**Library** TI C2000

### Description

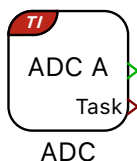

This block configures the ADC peripheral as a single-ended input with an internal voltage reference, or as a differential input. The ADC block output signal represents the measured voltage at the ADC pin (in single-ended mode), or as the difference between the measured voltage of the positive and negative ADC input pins (in differential mode). The output is scalable and can be used with an offset, where the output signal is calculated as  $\text{input} * \text{Scale} + \text{Offset}$ . When the **Analog input channel(s)** parameter is vectorized, each input channel is measured sequentially in the order of the input channel vector.

**Note** When used in differential mode, the **Analog input channel(s)** parameter (either as a single input or vectorized) should refer only to the positive input pin of that differential pair (i.e. to select the differential input utilizing ADCA0 as the positive input pin and ADCA1 as the negative input pin, simply put "0"). Also note that for offline simulation with differential mode, the ADC input port will take in both the positive and negative inputs in a vectorized form. Specifically, for an ADC configured for channels [4,6] the input vector should look like [ADCIN4P, ADCIN4N, ADCIN6P, ADCIN6N]. See below figures for an example.

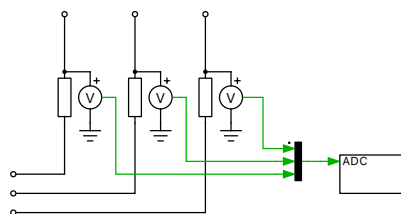

### Single-ended ADC offline model example

The **Trigger source** parameter selects between an automatic or external ADC start-of-conversion signal, where the external start-of-conversion signal is connected to the ADC trigger port. If the ADC task output is the source of a Con-

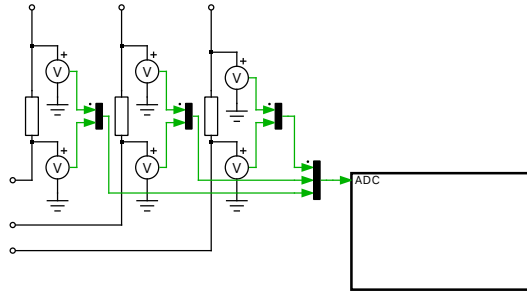

### Differential ADC offline model example

control Task Trigger then the control task will execute once the last ADC channel is converted.

## Parameters

### Main

#### Trigger source

Selects an automatic or external start-of-conversion trigger.

#### Signal mode

Selects between single-ended and differential conversion modes.

#### ADC unit

Selects the peripheral index for the ADC input when there are multiple ADC submodules.

#### Analog input channel(s)

Index of the analog input channel for a specific ADC submodule. For vectorized input signals a vector of input channel indices must be specified. For differential inputs, enter the input channel(s) corresponding to the (even numbered) positive input pin(s).

#### Scale(s)

A scale factor for the input signal.

#### Offset(s)

An offset for the scaled input signal.

#### Acquisition time

Selects between a minimal or user specified ADC acquisition time.

#### Acquisition time value(s)

Sets the ADC acquisition time window in seconds.

### **Offline only**

#### **Resolution**

The resolution of the offline ADC model in bits. The resolution is applied over the voltage reference range. If the parameter is left blank ADC quantization is not modeled.

#### **Voltage reference**

The voltage range of the offline ADC model used to determine the ADC resolution.

## CAN Port

**Purpose** Set up a CAN communication port. Supports both classic CAN 2.0 and CAN FD.

**Library** TI C2000

### Description



The block sets up a CAN (Controller Area Network) communication port. Both classic CAN (CAN 2.0) and CAN FD (CAN with flexible data-rate) protocols are supported.

The input **en** determines the CAN port state. Setting **en** to zero will force the CAN port to the *bus-off* state, while setting the port to 1 allows the CAN port to transition to *bus-on*. If Auto bus-on is not enabled, a *bus-off* condition has to be cleared by setting the enable signal to 0, and then back to 1.

#### Error Modes

The output **on** is 1 to signal *bus-on* status, 0 otherwise. The output **ea** is 1 to signal *error active* status, 0 otherwise.

All nodes on a CAN bus detect errors and maintain two error counters: a *Transmit Error Counter* and a *Receive Error Counter*. Each node can be in one of the following 3 error modes:

- **error active** This is the start mode of all the nodes, when both error counters are less than 128. In this mode, a node fully participates in bus communication and transmits an active error flag when it detects errors.
- **error passive** When one of the two error counters is greater than 127, a node goes into error passive mode. In this mode, a node still participates in bus activities, but transmits a passive error flag when it detects errors.
- **bus-off** When the *Transmit Error Counter* is greater than 255, a node goes into a bus-off mode. When in this mode, the node is disconnected from the bus and can no longer participate in bus activities. If Auto bus-on is not enabled, a bus-off condition has to be cleared by setting the enable signal to 0, and then back to 1. After recovering from bus-off condition, both the error counters are reset to 0 and the node goes into error active mode.

### Parameters

#### Main

##### CAN interface

Selects the CAN interface to use:

- CAN A and CAN B support the CAN 2.0 protocol.
- MCAN A and MCAN B (Modular Controller Area Network) support both CAN 2.0 and CAN FD protocols. CAN FD supports bit rates higher than 1 MBit/s (up to 2 MBit/s) and payloads larger than 8 bytes (up to 64 bytes).

### **GPIO [Rx, Tx]**

Specifies the GPIOs to use for CAN communication. Each CAN channel requires one receive (Rx) and one transmit (Tx) pin.

### **Auto bus-on**

The Auto bus-on feature, if enabled, will automatically clear a bus-off condition, without the need for setting the enable signal **en** to 0, and then back to 1.

### **Bit rate configuration**

**for CAN A/B:** The following parameters are configurable only when the **CAN interface** is set to CAN A or CAN B.

#### **Baud rate**

Defines the baud rate that is used on the connected CAN bus. All devices on a CAN bus must be configured to use the same baud rate.

#### **Bit sample point [%]**

Defines the point in time where the bus level is read and interpreted as the value.

**for MCAN A/B:** The following parameters are configurable only when the **CAN interface** is set to MCAN A or MCAN B.

#### **Bit rate switching**

Enables or disables the bit rate switching. When Enabled, the flexible data-rate offered by CAN FD is supported. When Disabled the data-rate is fixed.

#### **Nominal bit rate [bit/s]**

Defines the bit rate during the nominal phase (also known as arbitration phase) that is used on the connected CAN bus.

#### **Nominal bit sample point [%]**

Defines the point in time where the bus level is read and interpreted in the nominal phase.

#### **Data bit rate [bit/s]**

Defines the bit rate during the data phase that is used on the connected CAN bus. This parameter is only configurable when **Bit rate switching** is Enabled.

**Data bit sample point [%]**

Defines the point in time where the bus level is read and interpreted in the data phase. This parameter is only configurable when **Bit rate switching** is Enabled.

**Advanced**

The bit time is divided into four segments, which are the Synchronization Segment (Syn\_Seg), Propagation Time Segment (Prop\_Seg), Phase Buffer Segment 1 (Phase\_Seg1), and Phase Buffer Segment 2 (Phase\_Seg2). These segments consist of a specific, programmable number of time quanta, with the length of each time quantum (Tq) determined by the CAN controller's system clock (CAN\_CLK) and the bit rate prescaler (BRP) according to the equation  $tq = BRP / CAN\_CLK$ . A diagram of the four segments is shown below:

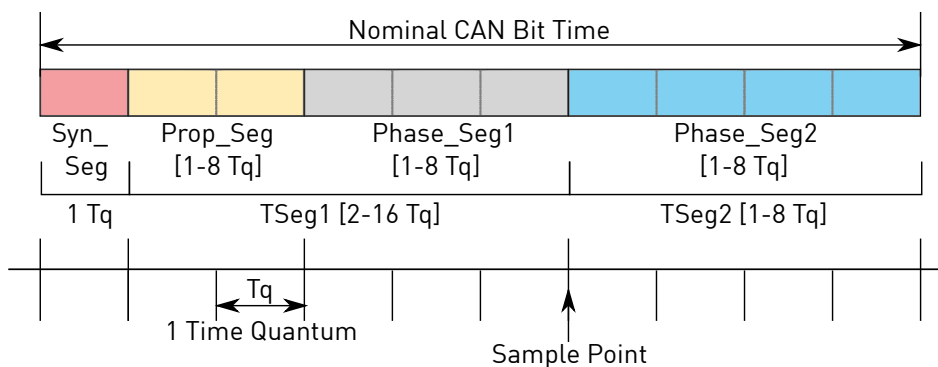
**CAN Bit Timing**

**Default configuration** If **Advanced configuration** is set to Disabled, the bit timing will be automatically deduced from the configured bit rate and sampling point. The following *default* configuration will be used:

- **Nominal/Data rate bit length** is maximized to have as much as possible time quanta to construct a bit time. This will result in a low bit rate prescaler (BRP).
- **Nominal/Data SJW** is chosen to be as large as possible.
- **SSP offset** is set to be in the middle of the data bit:  
 $(1 + Tseg1 + Tseg2)/2$
- **SSP filter** is set to 0.

**Advanced configuration** If **Advanced configuration** is set to Enabled, then advanced bit timing settings can be configured.

**for CAN A/B:** The following parameters are configurable only when the **CAN interface** is set to CAN A or CAN B.

**Bit length [1+Tseg1+Tseg2]**

Defines the sum of all bit time segments expressed in time quanta as  $1 + T_{seg1} + T_{seg2}$

**SJW [Tq]**

Synchronization jump width expressed in time quanta.

**for MCAN A/B:** The following parameters are configurable only when the **CAN interface** is set to MCAN A or MCAN B.

**Nominal rate bit length [1+Tseg1+Tseg2]**

Defines the sum of all bit time segments during the nominal phase expressed in time quanta as  $1 + T_{seg1} + T_{seg2}$

**Nominal rate SJW [Tq]**

Synchronization jump width during nominal phase expressed in time quanta.

**for MCAN A/B with Bit Rate Switching:** The following parameters are configurable only when the **CAN interface** is set to MCAN A or MCAN B and the **Bit rate switching** is Enabled.

**Data rate bit length [1+Tseg1+Tseg2]**

Defines the sum of all bit time segments during the data phase expressed in time quanta as  $1 + T_{seg1} + T_{seg2}$

**Data rate SJW [Tq]**

Synchronization jump width during data phase expressed in time quanta.

**Secondary sampling point (SSP)**

If set to Enabled advanced secondary sampling point settings can be configured and the automatic transceiver delay compensation is enabled.

**SSP offset [Tq]**

Defines the secondary sampling point offset expressed in time quanta.

**SSP filter [Tq]**

Defines the secondary sampling point filter expressed in time quanta.

## CAN Receive

**Purpose** Receive CAN messages

**Library** TI C2000

### Description

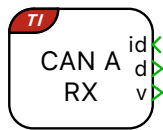

CAN Receive

The block initiates the reception of CAN messages with the given identifier (ID) on the given CAN interface. On reception of a CAN message the data is made available on the block output **d** as a vectorized signal of the provided frame length. The reported value is latched from the most recent valid timestep. The output **v** is 1 in for one simulation step when new data is received, 0 otherwise. The output **f** is only shown and relevant when MCAN is used and configured in the CAN Port (see page 55) block. The output **f** is a vectorized signal containing the following information for each configured message:

- The first signal specifies the error state indicator. If the signal is 0, the transmitting node is error passive, and it is 1 when the node is error active.
- The second signal indicates whether the Rx frame was received in classic (0) or FD (1) format.
- The third signal indicates whether the Rx frame was received without (0) or with (1) bit rate switching.

---

**Note** To ensure the most recent data on the CAN bus is reported, the CAN Receive block must execute in a task at a higher rate than the the message is transmitted on the CAN bus.

---

### Parameters

#### CAN interface

Selects the CAN interface to use. The selected CAN interface must be configured using a CAN Port (see page 55) block.

#### CAN ID source

Selects whether the CAN ID is specified as a parameter or is supplied as an input signal.

#### CAN ID

The ID for which the block receives CAN messages. The CAN ID can be supplied as either a 11-bit value (for CAN 2.0A) or a 29-bit value (for CAN 2.0B).

### **Frame format**

Specifies the frame format that is used when filtering for matching CAN messages. Possible values are:

- Base for CAN 2.0A messages with an 11-bit ID. The standard 11-bit ID provides for  $2^{11}$ , or 2048 different message identifiers.
- Extended for CAN 2.0B messages with an 29-bit ID. The extended 29-bit ID provides for  $2^{29}$ , or 537 million identifiers.
- **Auto** uses the **Standard** format if the specified **CAN ID** is smaller than 2047. Otherwise, the **Extended** format is used.

### **Frame length**

Specifies the frame length of the CAN message in bytes.

### **Offline simulation**

Enables or disables data inspection in an offline simulation. If set to **enable**, terminals are added to the subsystem in the top-level schematic. If set to **disable**, no such terminals are added to the subsystem.

## CAN Transmit

**Purpose** Transmit CAN messages

**Library** TI C2000

### Description



CAN Transmit

The CAN Transmit block sends out data on a CAN bus. The data to send must be provided on the block input **d** as a vectorized signal with data type **uint8**. The length of the transmitted CAN message is determined by the width of the input signal (1 to 8 bytes).

Messages are either sent regularly with a fixed sample time or on demand when the trigger input changes. When configured for triggered execution, messages are sent when the trigger signal changes in the manner specified by the **Trigger type** parameter:

#### **rising**

Data is sent when the trigger signal changes from 0 to a non-zero value.

#### **falling**

Data is sent when the trigger signal changes from a non-zero value to 0.

#### **either**

Data is sent when the trigger signal changes from 0 to a non-zero value or vice versa.

### Parameters

#### **CAN interface**

Selects the CAN interface to use. The selected CAN interface must be configured using a CAN Port (see page 55) block.

#### **CAN ID source**

Selects whether the CAN identifier (ID) is specified as a parameter or is supplied as an input signal.

#### **CAN ID**

The ID that is used for CAN messages sent by this block. The CAN ID can be supplied as either an 11-bit value (for CAN 2.0A) or a 29-bit value (for CAN 2.0B).

#### **Frame format**

Specifies the frame format of the CAN messages to be transmitted. Possible values are:

- Base for CAN 2.0A messages with an 11-bit ID. The standard 11-bit ID provides for  $2^{11}$ , or 2048 different message identifiers.

- Extended for CAN 2.0B messages with an 29-bit ID. The extended 29-bit ID provides for  $2^{29}$ , or 537 million identifiers.
- **Auto** uses the **Standard** format if the specified **CAN ID** is smaller than 2047. Otherwise, the **Extended** format is used.

### **Bit rate switching**

This option is configurable only when the **CAN interface** is set to MCAN. When Enabled, the flexible data-rate offered by CAN FD is used. When Disabled the data-rate is fixed.

### **Execution**

Selects between **regular** and **triggered** execution.

### **Trigger type**

The direction of the edges of the trigger signal upon which the data is sent, as described above (for triggered execution only).

### **Offline simulation**

Enables or disables data inspection in an offline simulation. If set to **enable**, terminals are added to the subsystem in the top-level schematic. If set to **disable**, no such terminals are added to the subsystem.

## Comparator

**Purpose** Compare analog input to reference and generate trip signal

**Library** TI C2000

**Description** This block encapsulates the principal features of the TI C2000 Comparator Subsystem (CMPSS) peripheral.

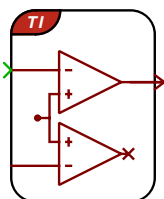

Comparator

It realizes an analog comparison between an external signal and an internal reference. The output of the block represents a "trip" signal, that can be connected to a PWM block for cycle-by-cycle control and timebase synchronization.

The internal reference signal, applied to the negative input of the comparator, is adjusted via the signal inport of the block. Additionally, a ramp can be superimposed onto the reference signal (e.g. for slope compensation). Such a ramp requires a synchronization signal, which must be provided by the peripheral synchronization output of a PWM block.

## Parameters

### Main

#### Sense input

Selects the desired sense input: ADC input or PGA input.

#### ADC unit

Selects the peripheral index for the ADC input when there are multiple ADC submodules.

#### ADC input channel

Index of the analog input channel for a specific ADC submodule. For vectorized input signals a vector of input channel indices must be specified.

#### PGA unit

Configures the Programmable Gain Amplifiers that are present on 28004x devices.

#### Active Comparators

Configures whether the CMPSS module uses only the high-side comparator or both the high-side and low-side comparators.

### COMP

#### **Polarity**

Allows inverting the output of the comparator in order to generate trip signals on negative compare edges.

#### **Ramp generator**

Allows enabling a ramp generator that is superimposed onto the reference signal.

#### **Ramp slope (absolute value)[V/s]**

Defines the ramp slope rate in Volts per second (V/s). The ramp counts down when **Polarity** is set to non-inverting and counts up when set to inverting.

## Control Task Trigger

**Purpose** Specify the base sample time and trigger for the main control task

**Library** TI C2000

### Description



The digital control loop executes at a nominal base sample time. The input to the Control Task Trigger specifies the interrupt that triggers a control loop execution. The source of the interrupt can be from the ADC end-of-conversion signal, PWM counter underflow and overflow events, or the Timer block. When a Control Task Trigger is not included in the subsystem an appropriate trigger source is automatically determined.

In a multi-tasking mode (defined in the Scheduling tab of the Coder Options dialog), the Control Task Trigger block triggers the Base task associated with the base sample time.

The offline simulation will model the impact of controller discretization when the Control Task Trigger is included. For offline simulations the Forward Euler method with the nominal base sample time is used to integrate continuous states within the subsystem containing the Control Task Trigger. Offline simulations will use the default subsystem execution settings when the Control Task Trigger block is not included in the subsystem.

### Parameters

#### Nominal base sample time

Specifies the nominal sample time of the discretized model in seconds. The nominal base sample time value is synchronized with the model **Discretization step size** of the PLECS Coder settings.

## CSV

**Purpose** Format data using CSV conventions and transmit it over a serial interface.

**Library** TI C2000

**Description** This block streams CSV-formatted data to a serial communication interface (SCI) or universal asynchronous receiver/transmitter (UART) for data logging or subsequent post-processing.

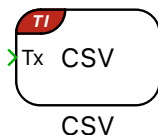

---

**Note** In order to format data before sending, the compiler needs to include additional C libraries that increase the size of the code significantly. As a result, running models that utilize the CSV block out of RAM is not currently supported. Models using the CSV block will likely not fit in RAM, which can lead to compilation errors.

---

The CSV block takes at its input an arbitrary number of multiplexed signals. These signals are captured at either the task rate, or at a rate controlled by the **trigger** port. The **trigger** is always set to rising-edge mode. When capturing, the CSV block stores all of its input signals simultaneously, guaranteeing that all signals in a row are from the same timestep. Lines of data can optionally be prefixed with a **timestamp**.

The CSV block transmissions are executed in the background task at the lowest priority in order to keep them from interfering with critical tasks being executed by the device. If there are insufficient processor cycles available to transmit the CSV data at the rate at which it is captured, data sets may get overwritten and lost, resulting in gaps between samples or no transmissions at all. If this occurs, reducing the sampling frequency and/or the number of samples being collected per timestep may help.

Most C2000 MCUs have either an SCI or UART peripheral. In the case where an MCU has access to both, the peripheral is chosen dynamically based on the pins requested in the block dialogue, with preference for UART.

### Parameters

#### Tx Mode

Select between **Standard** and **Triggered** operating modes. **Standard** mode takes samples at the same rate as the task containing the block; **Triggered** takes samples at the rising edge of a provided clock.

**Serial [Rx, Tx]**

Configure the serial peripheral to use the provided Rx (receive) and Tx (transmit) pins.

**Baud Rate**

Serial communication rate in bits/s.

**Separator**

Configure CSV separator character as **comma, semicolon, space** or **tab**.

**Newline Character**

Configure newline character to **LF, CRLF** or **None**.

**Enable Timestamps**

Enable or disable the sending of a timestamp along with each line of CSV data. If enabled, the timestamp will be sent as the first datapoint of each row. The timestamp is **not** sent pre-converted to units of time, rather, it represents the number of the model timestep it was taken from. To convert to a unit of time, multiply the timestamp by the task rate associated with the CSV block.

# CPU Load

**Purpose** Provide the CPU load in percent

**Library** TI C2000

**Description** This block outputs the percentage of time that is used by the control task with one interrupt period. In case of multi-tasking, the output corresponds to the Base task load, and does not include the load created by additional lower-priority tasks.

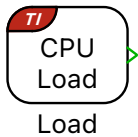

## DAC

**Purpose** Generate an output voltage from the input signal; the output voltage is calculated as  $\text{input} * \text{Scale} + \text{Offset}$

**Library** TI C2000

**Description** This block generates a voltage on the DAC pin in the range of 0 V to 3.3 V. The output is scalable and can be used with an offset, where the output signal is calculated as  $\text{input} * \text{Scale} + \text{Offset}$ . Output voltage limitations can also be set.

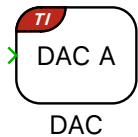

**Parameters**

**DAC Unit**  
Selects the peripheral index for the DAC input when there are multiple DAC submodules.

**Scale**  
A scale factor for the output signal.

**Offset**  
An offset for the scaled output signal.

**Minimum output voltage**  
The lowest value that the output voltage can reach.

**Maximum output voltage**  
The highest value that the output voltage can reach.

# Digital In

**Purpose** Read a digital input

**Library** TI C2000

## Description



Digital In

The output signal is 1 if the input voltage is higher than the high level input voltage threshold,  $V_{IH}$ , and 0 if it is lower than the low-level input voltage,  $V_{IL}$ . For other input voltages the output signal is undefined. Refer to the device data sheet for the electrical characteristics of a specific target. During an offline simulation the block behaves like a simple feedthrough.

## Parameters

### Digital input GPIO resource(s)

Defines the GPIO resource of the digital input channel. For vectorized input signals a vector of input channel indices must be specified.

### Input characteristic

Specifies whether an internal Pull-up resistor is connected to the digital input.

## Digital Out

**Purpose** Set a digital output

**Library** TI C2000

**Description** The output is set low if the input signal is zero and is set high for all other values. During an offline simulation the block behaves like a simple feedthrough.



Digital Out

### Parameters

#### Digital output GPIO resources(s)

Defines the GPIO resource of the digital output channel. For vectorized output signals a vector of output channel indices must be specified.

#### Output characteristic

Specifies whether an internal Push-pull or Open drain resistor is connected to the digital output.

# External Sync

**Purpose** Set up an external synchronization port for PWM output

**Library** TI C2000

### Description



External Sync

The PWM (Variable) block can synchronize the PWM carrier phase with an external GPIO signal. This block is used to model the external synchronization input in offline simulations, and to specify the GPIO pin used for PWM synchronization when generating code.

Note that the number of allowable External Sync blocks is limited according to the hardware capabilities of the target MCU.

### Parameters

#### External GPIO

Defines the GPIO used to synchronize the PWM with an external source.

## Offline Inport

**Purpose** Create a target inport for offline simulation

**Library** TI C2000

**Description** This convenience block enables external signal connections to the code generation subsystem for analysis and testing during offline simulations. For code generation, it is replaced by a constant zero vector.



Offline Inport

# Offline Output

**Purpose** Create a target outport for offline simulation

**Library** TI C2000

**Description** This convenience block enables signal connections from the code generation subsystem to external components for analysis and testing during offline simulations. It is ignored for code generation.



Offline Output

## Override Probe

**Purpose** Allow modifying input value during a PIL simulation

**Library** TI C2000

**Description** During a PLECS processor-in-the-loop (PIL) simulation, an Override Probe allows PLECS to overwrite variables in the embedded code.

For further details on the PIL simulation, refer to the PIL User Manual.

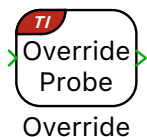

## Peak Current Controller

**Purpose** Implement peak current control with ramp compensation

**Library** TI C2000

**Description** The Peak Current Controller (PCC) block implements peak current control with slope compensation.

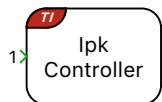

Peak Current Controller

In a peak current-mode controller, at the beginning of each switching cycle the output is set (gate signal is turned ON) without a pre-determined duty cycle. Then, when the sensed inductor current exceeds the peak current reference value, the output is reset (gate signal is turned OFF). The duty cycle is therefore determined by the rise of the inductor current during the on-time.

One of the drawbacks of the peak current-mode controller is that it suffers from an inherent instability if the applied PWM duty cycle is greater than 50%. This is explained in the figure titled “Slope compensation”. If a small disturbance is introduced into the system and if the applied duty cycle is less than 50%, the disturbance eventually decays to zero. However, if the applied duty cycle is greater than 50%, the inductor current will start to diverge and will no longer be stable. The resulting duty cycle values will vary from small to large, on an alternating cycle basis, called sub-harmonic oscillations. To limit these sub-harmonic oscillations, instead of providing a constant peak current reference, additional slope compensation is applied, which then ensures the stability of the inductor current.

Internally, the PCC block makes use of multiple MCU peripherals. The first component is a DAC that provides a peak current set-point including ramp, for controlling the inductor current. The second is a comparator (COMP); the sensed current is fed to the comparator, which is then compared to the peak current set-point provided by the DAC. The output of the COMP block is fed to the third component, which is the PWM generator. The PWM generator generates the PWM waveforms at the specified frequency.

### Parameters

#### Main

#### PWM generator

Selects the index of the PWM resources to use. The PWM generator can independently generate a single PWM output or a complementary PWM pair.

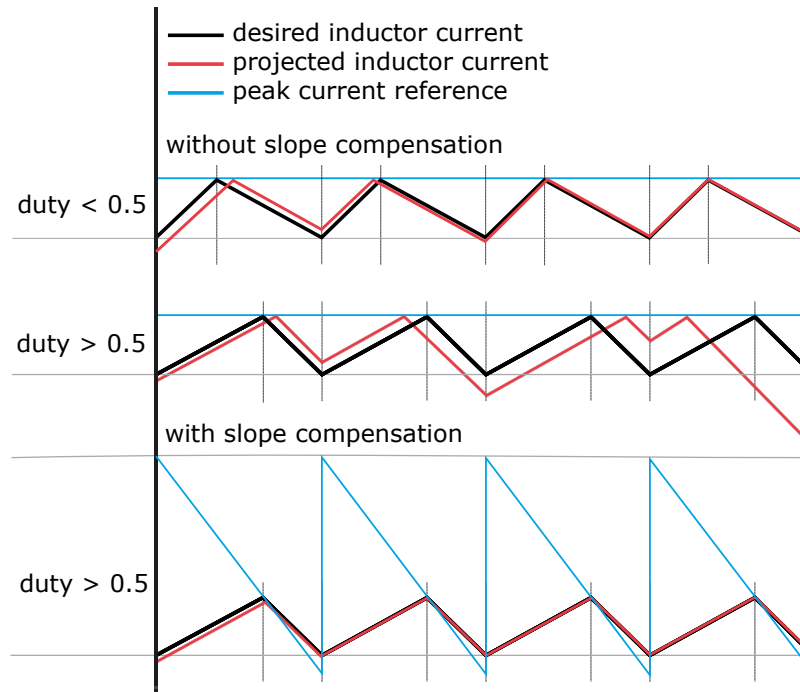

### Slope compensation

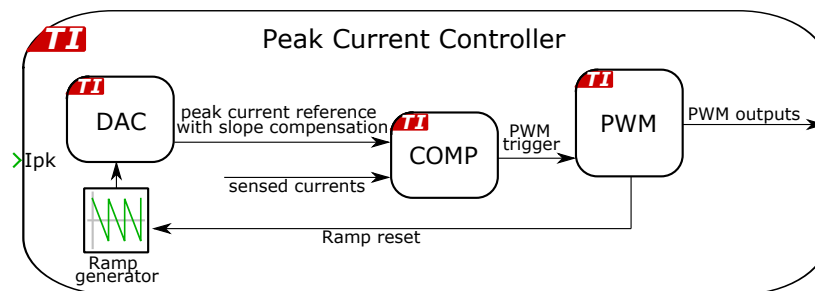

### Peak current controller schematic

#### Carrier frequency

Defines the switching frequency of the output signal in Hertz (Hz).

#### Frequency tolerance

Specifies the behavior when the desired carrier frequency is not achievable

based on the system clock frequency.

### **Sense input**

Selects the desired sense input: ADC input or PGA input.

### **ADC unit**

Selects the peripheral index for the ADC input when there are multiple ADC submodules.

### **ADC input channel**

Index of the analog input channel for a specific ADC submodule. For vectorized input signals a vector of input channel indices must be specified.

### **PGA unit**

Configures the Programmable Gain Amplifiers that are present on 28004x devices.

### **Current sense gain**

Scales the peak current reference ( $I_{pk}$ ) into values with physical units to be used for the control algorithm.

### **Ramp slope**

Defines ramp slope rate in Amperes per second (A/s). Slope compensation can be applied to ensure stability when the output duty cycle exceeds 50%. Entering a parameter,  $I_{ramp}$ , reduces  $I_{pk}$  during each switching cycle as follows:  $I'_{pk} = I_{pk} - I_{ramp} \cdot t$ , where  $T$  is the time elapsed from the start of the switching cycle. Slope compensation can be omitted by setting  $I_{ramp}$  to 0.

### **Ramp offset**

Defines ramp offset in Amperes (A).

### **Leading edge blanking time**

This sets the minimum output on time at the beginning of each switching period in seconds (s). Leading edge blanking time is used to prevent the turn-on transient current from triggering the peak current controller.

## **Output**

### **Mode**

- **Complementary outputs** operates channels A & B in complementary fashion with dead time.
- **Single output (channel A)** only modulates channel A and allows the GPIO of channel B to be used for other purposes.

**Dead time**

Delay between the rising and falling edges of a complementary PWM output pair in seconds (s).

**Polarity**

Defines the logical output of the ePWMxA output when an active state is detected. The active state occurs when the modulation index exceeds the carrier. Note that ePWMxB is always complementary to ePWMxA.

**Events****ADC trigger**

Configures the ADC trigger output.

**ADC trigger divider**

Determines how many events need to occur before an ADC trigger is generated.

**Task trigger**

Configures the control task trigger output.

**Task trigger divider**

Determines how many events need to occur before a Task trigger is generated.

**Offline only****System clock frequency (SYSCLK)[MHz]**

Defines the system clock frequency in MHz for offline simulations. For real-time simulations, the PCC block uses the system clock frequency parameter specified in the Target tab of the Coder Options dialog.

## Powerstage Protection

**Purpose** Provide powerstage safety features

**Library** TI C2000

### Description

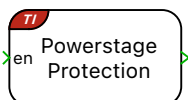

Powerstage Protection

The Powerstage Protection block implements an interlock, which is a safety mechanism, to enable or disable all the PWM outputs on the target device. The PWM outputs are disabled unless there is a logical low to high transition on the input signal, labeled **en**. This prevents the PWM signals from becoming active as soon as the code is executed on the target, thereby ensuring safe operation.

Additionally, there is an option to configure a GPIO (digital output) as a powerstage enable signal. This signal can then be used, for example, to provide an enable signal to external gate driver chips. The **Powerstage enable polarity** of the output GPIO pin, specified in the **Powerstage enable GPIO number** can be defined as:

- **Active low:** a logical low to high transition on the input signal, **en**, sets the GPIO pin to logic low (0).
- **Active high:** a logical low to high transition on the input signal, **en**, sets the GPIO pin to logic high (1).

To reiterate, the powerstage enable signal (GPIO out) is an output signal of the Powerstage Protection block. This signal does not contribute to enabling or disabling PWM outputs, and can be considered as a status indicator of the Powerstage Protection interlock state. Irrespective of the configuration of this signal (Digital output or None), the Powerstage Protection block, if included in the schematic, disables all the PWM outputs on the target device, unless there is a logical low to high transition on the input signal, labeled **en**.

If the Powerstage Protection block is omitted from the schematic, then all PWM outputs will be continuously enabled.

### Protection

**Digital trips:** The trip zone submodule can be used to disable the powerstage and associated PWM blocks following a trip event. Trip events are detected when there is an active low condition on the trip zone GPIO inputs assigned in the **Protections** tab of the **Coder + Coder Options + Target** window. When a trip event is detected the Powerstage Protection module can take no action,

activate a one-shot trip event, or activate a cycle-by-cycle trip event. A one-shot trip event will latch the PWM output to the PWM safe state and can only be cleared by cycling the Powerstage Protection block from *disabled* to *enabled*. Cycle-by-cycle trip events will set the PWM output to the PWM safe state until the PWM counter reaches an underflow event. At the PWM counter underflow the trip condition will be cleared if the trip zone input is no longer active. The cycle-by-cycle trip event will attempt to clear the trip condition once per PWM cycle. The **PWM safe state** is a configuration of the Powerstage Protection block.

**Analog trips:** Each analog trip can be configured in the **Protections** tab of the **Coder + Coder Options + Target** window to emit one of three specific trip signals (labeled A, B, or C). When a trip signal is detected the Powerstage Protection module can take no action or activate a one-shot trip event. A one-shot trip event will disable the powerstage (setting the PWM outputs to the configured **PWM safe state**). All trip events are latched and can only be cleared by cycling the Powerstage Protection block from *disabled* to *enabled*.

## Timing

When the Powerstage Protection **en** input is activated, the digital output (GPIO out) associated with the block (if configured) will immediately become active to e.g. enable a gate driver chip. However, the actual PWM signals will remain disabled for 100 ms to allow the gate driver circuit to stabilize. During this period the signal output of the Powerstage Protection block will remain low. Only at the end of the 100 ms delay will the signal output transition to high, simultaneously with the PWM signals becoming active. Therefore, a regulator reset or anti-windup mechanism must be controlled by the output signal of the Powerstage Protection block (signal out), and not the **en** input.

## Parameters

### Main

#### Powerstage enable signal

Provides an option to configure a GPIO (digital output) as a powerstage enable signal.

- **Digital output:** Configures a GPIO (digital output) as a powerstage enable signal. This signal can then be used, for example, to provide an enable signal to external gate driver chips. This signal can be considered as a status indicator of the Powerstage Protection interlock state.
- **None:** Powerstage enable signal is not configured.

PLECS top-level schematic

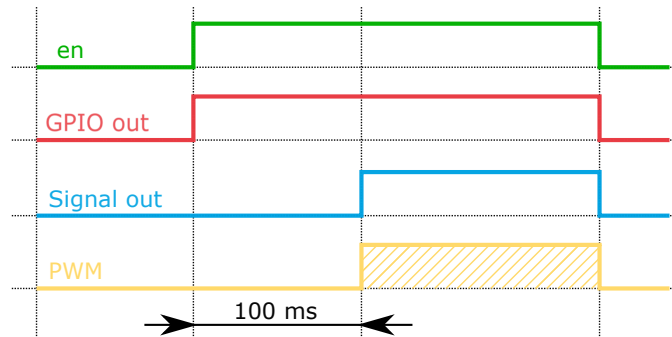
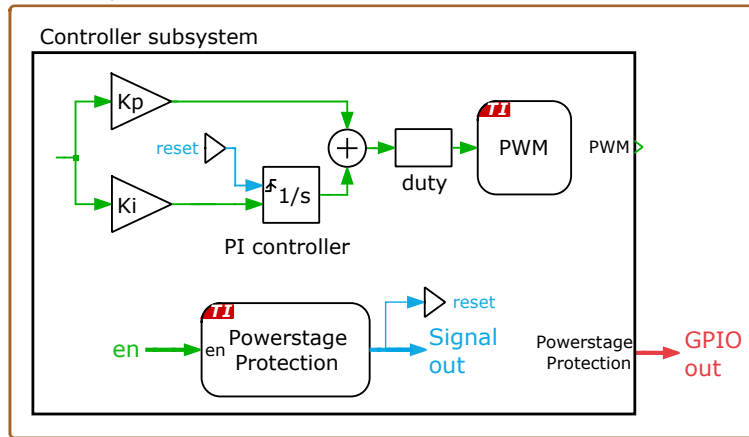

### Powerstage Protection timing

#### Powerstage enable polarity

Defines the polarity of the powerstage enable signal.

- **Active low:** a logical low to high transition on the input signal, **en**, sets the GPIO pin to logic low (0).
- **Active high:** a logical low to high transition on the input signal, **en**, sets the GPIO pin to logic high (1).

#### Powerstage enable GPIO number

Defines the GPIO pin to be configured as the powerstage enable signal.

#### PWM safe state

Specifies the forced PWM output state when a trip zone is triggered. Select-

ing the forced inactive option drives all associated PWM outputs the passive state. Selecting the floating option sets the associated PWM outputs to a high impedance state.

## Protection

### Reaction to TZ1

Selects the action following a digital trip zone event.

### Reaction to TZ2

Selects the action following a digital trip zone event.

### Reaction to TZ3

Selects the action following a digital trip zone event.

### Reaction to trip signal A

Selects the action following an analog trip event detection.

### Reaction to trip signal B

Selects the action following an analog trip event detection.

### Reaction to trip signal C

Selects the action following an analog trip event detection.

## Offline only

### Interlock

For convenience, the interlock can be enabled or disabled for offline simulations.

- Select **Simulate** to enable the simulation of the interlock safety mechanism. The output of the the Powerstage Protection block in the top-level schematic is disabled unless there is a logical low to high transition on the input **en**.
- Select **Do not Simulate** to disable the simulation of the interlock mechanism. The output of the the Powerstage Protection block can then be enabled at the start of the simulation by tying **en** to 1.

**Note** that the offline model of the Powerstage Protection block only simulates the powerstage interlock mechanism, in conjunction with the block output and the **Powerstage enable signal** digital output (GPIO).

The effect that the Powerstage Protection block has on the individual PWM signals is not represented in an offline simulation, and needs to be separately implemented by the user. An example is shown in the figure below.

The **Powerstage enable signal** digital output is wired to a PWM enable/disable Signal Switch, thereby simulating the enable signal of a gate driver circuit. This logic is used in a few of the TI C2000 Target Support Demos.

Top-level schematic

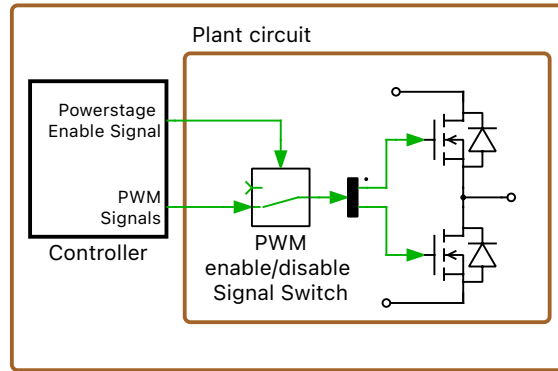

**An offline implementation of the gate driver logic of the Powerstage Protection block**

## Pulse Capture

**Purpose** Time-stamp edges of a pulse train

**Library** TI C2000

### Description

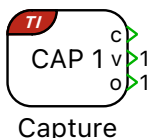

The capture blocks allows time-stamping signal transitions (events) on input pins, e.g. for period and/or duty cycle measurements. The timestamps are made available on the block output **c**.

The output **v** is 1 for one simulation step after all events have been triggered, 0 otherwise. The output **o** is set to 1 should the timestamp counter overflow. After a counter overflow, the counter resets to 0 and continues to count up. The output **o** is automatically cleared after it has been read.

Events can be captured individually for either *absolute time-stamp mode* or *time-difference mode*.

In *absolute time-stamp mode*, the timestamp counter continues incrementing after the capture event occurs.

In *time-difference mode*, the timestamp counter is reset when the event occurs. This feature simplifies determining elapsed time between events.

Depending on the eCAP type, the behavior of the capture block can vary. There are three eCAP types: Type-0, Type-1 and Type-2.

With Type-0 eCAP, as implemented in TI2806x, TI2833x and TI2837x MCUs, the reset actions of events continue even after a full set of events is received.

With Type-1 eCAP, as present on TI28004x MCUs, once a full set of events is received, the reset actions of events do not continue. The counter will therefore count-up without resetting until after the next model step, when the capture results are read and the module is re-armed, resulting in a large count value for the first event.

Type-2 and higher eCAPs as present on TI2838x, TI28003x, TI28P55x, and TI28P65x MCUs, behave like Type-1 eCAP from a reset event perspective.

The figure below illustrates this with an example for the three events described in the following table:

Event	Trigger	Reset Counter	CAP Output
Event 1 (E1)	Falling	True	C1
Event 2 (E2)	Rising	False	C2
Event 3 (E3)	Falling	True	C3

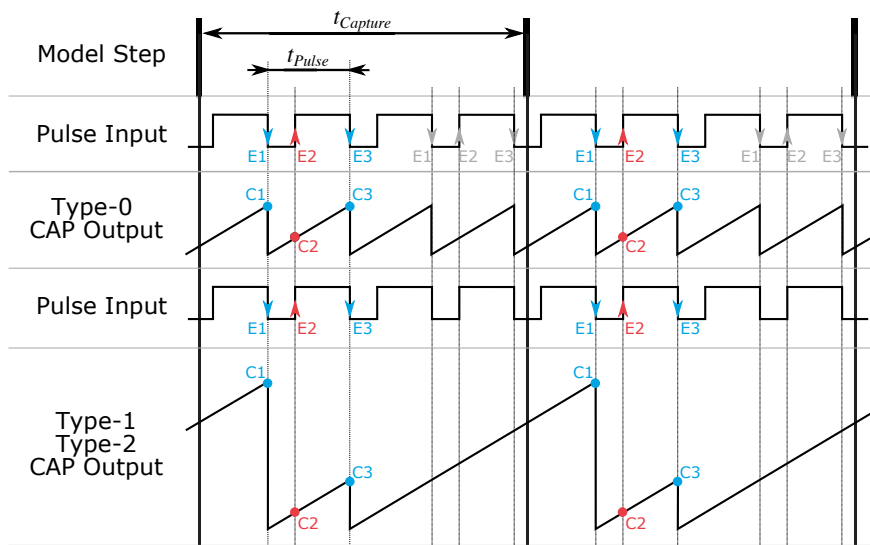

**An illustrative example of Type-0 and Type-1 CAP outputs**

In the figure above,  $t_{\text{Capture}}$  is the execution step size of the eCAP block and  $t_{\text{Pulse}}$  is the period of the captured pulse train.

In case of Type-0 eCAP, even after the full set of events E1, E2 and E3 are received, the reset actions for the next set of events within the same model step continue. Therefore, in this case, the outputs C1 and C3 are the same.

In case of Type-1 and Type-2 eCAP modules, once the full set of events E1, E2 and E3 are received, the counter continues to count-up until the next trigger event in the next model step, resulting in a large value for C1.

## Parameters

## Main

### **CAP module**

Selects the eCAP module to use.

### **Input GPIO number**

Defines the GPIO pin number associated with the chosen eCAP module.

### **Prescaling**

Provides an option to disable or enable prescaling an input capture signal (pulse train).

### **Prescale value**

Specifies the desired prescale value. A pulse train can be prescaled by  $N = 2-62$  (in multiples of 2).

## Events

### **Event**

Provides an option to define four capture events. Polarity can be set to trigger on Rising or Falling edge. Unused events can be Disabled.

### **Reset counter on Event**

Events can be captured in absolute time-stamp mode with reset counter set to false or in time-difference mode with reset counter set to true.

## Offline only

### **System clock frequency (SYSCLK)[MHz]**

Defines the system clock frequency in MHz for offline simulations. For real-time simulations, the capture block uses the system clock frequency parameter specified in the Target tab of the Coder Options dialog.

### **eCAP type**

Allows choosing either a Type-0 or a Type-1 and above eCAP behavior for offline simulation.

# PWM

**Purpose** Generate a PWM signal

**Library** TI C2000

**Description**

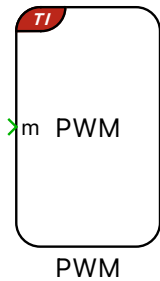

The PWM block can generate a complementary output, a single output, or a dual output on one or multiple PWM generators. The modulation index for each PWM generator or channel must be provided via the input signal **m** (or **A** and **B**). If multiple generators are used, then the input signal must be vectorized. The carrier starts at 0 and varies between 0 and 1. During an offline simulation, the PWM block emulates the detailed behavior of the MCU ePWM peripheral very accurately.

The active/passive sequence of the PWM pattern is configurable. A positive sequence modulation begins with the active state at carrier underflow. In case of a negative sequence, the PWM pattern begins with a passive state.

The PWM block can configure independent interrupts to trigger the ADC start-of-conversion and the Control Task Trigger. Interrupts are synchronized with the PWM carrier and will occur at the carrier underflow, overflow, or underflow and overflow events. The underflow and overflow events correspond to the PWM carrier reaching the respective minimum or maximum carrier values.

The figure below shows an example of a symmetric PWM carrier with the task trigger set to underflow, the ADC trigger set to overflow, the polarity configured with an active state logic of '1' and the PWM sequence set to positive.

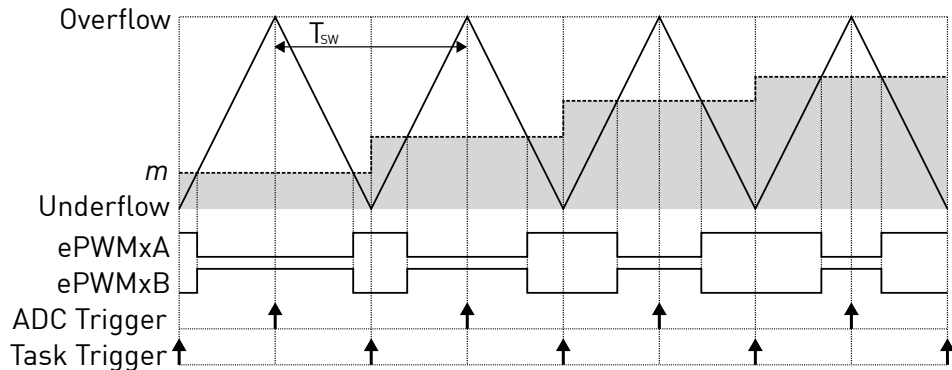

**PWM and trigger schemes for symmetric carrier**

The PWM block also supports **high resolution** modes for duty cycle, period, and dead time. Ordinarily, these values are rounded to the closest step achievable by the PWM clock. High resolution mode allows these values to be quantized at 256 times the resolution of the PWM clock, achieving much more accurate results at high switching frequencies. Utilizing this functionality will impose some notable limitations:

- Variable and custom **Sequence** may not be used with high resolution duty cycle or period enabled.
- Symmetrical **Carrier type** may not be used with high resolution period enabled.
- Duty cycle of 0 is unachievable with high resolution period enabled.
- **Compare load** in the **Shadowing** menu will be disabled when high resolution period is enabled (enforced to **Overflow**).

For expert users, this block offers fixed and variable Action-Qualifier (AQ) based sequence configurations to allow the generation of advanced PWM patterns. When an AQ-based sequence is enabled, the sequence value directly defines the PWM actions at specific timebase and compare events. The AQ value provided as a parameter, or at the AQ port, is written to both the AQCTLA and AQCTLB registers, with the distinction that CMPB related actions are masked from AQCTLA and, similarly, CMPA actions are masked from AQCTLB. Note that AQCTLB is only relevant if Dual output (channel A & B) has been selected as the PWM **Mode**.

Please refer to the TI Technical Reference Manual for more detailed information about the AQ Submodule and the AQCTLA/B register layout.

---

**Note** For regular PWM sequences, the modulation inputs **m**, **A** and **B** specify the relative duration of the active state. However, when AQ-based sequences are selected, **m** sets the relative CMPA value. In case of Dual output (channel A & B) operation, the modulation inputs **A** and **B** correspond to the relative CMPA and CMPB values, respectively.

---

## Parameters

### Main

#### PWM generator(s)

Index of the PWM resources. For vectorized output signals a vector of output channel indices must be specified.

### **Carrier type**

Selects the carrier waveform, either sawtooth or symmetrical.

### **Carrier frequency**

Defines the frequency of the carrier in hertz (Hz).

### **Frequency tolerance**

Specifies the behavior when the desired carrier frequency is not achievable based on the system clock frequency.

### **Phase(s)**

Specifies the phase shift in p.u. for each PWM generator. If the block is self-synchronized, the phase shifts are referenced to the first PWM generator, and the phase value of the first generator must be set to 0. In case of external synchronization, the phase shifts are with respect to the synchronization signal. This field can be left empty if no phase shifts are desired.

## **Output**

### **Mode**

- Complementary outputs operates channels A & B in complementary fashion with dead time.
- Single output (channel A) only modulates channel A and allows the GPIO of channel B to be used for other purposes.
- Dual output (channel A & B) allows channel A and channel B to be modulated individually, and the modulation index for each channel must be provided separately via their respective input ports **A** and **B**.
- Outputs disabled does not generated any PWM outputs. The GPIO of both channels remain free to be used for other purposes.

### **Dead time variation**

If enabled, an additional input port **d[r,f]** is displayed to allow variation of the rising-edge and falling-edge delays. This port expects:

- A vector of size 2 to set equal rising and falling delays for all channels, or
- A vector with a size equal to the number of PWM output channels, containing a sequence of d[r,f] pairs.

The units of the d[r,f] inputs are seconds.

### **Dead time [s]**

If generating complementary outputs, dead time is the delay between the rising and falling edges of the PWM output pair. For a single output, it

is the turn-on delay of the PWM output. Dead time is to be specified in seconds. This parameter is only applicable if dead time variation is disabled.

#### **Minimal dead time [s]**

The parameter specifies the minimal dead time when variable dead time is enabled.

#### **Polarity**

Defines the logical output corresponding to the active state.

#### **Sequence**

- A Positive sequence produces a PWM pattern that starts with the active state.
- The Negative sequence begins with the passive state, resulting in a pattern that is phase shifted by 180 degrees compared to the positive sequence.
- An additional component port **seq** is created if **Sequence** is set to Variable. Applying a signal  $> 0$  to this port sets the sequence to positive.
- The Fixed AQ (Expert Mode) configures PWM patterns according to the **Fixed AQ sequence(s)** parameter, which is applied to the AQCTLA/B registers as described above.
- An additional component port **AQ** is created if **Sequence** is set to Variable AQ (Expert Mode). As described above, the value at the **AQ** port is applied to the AQCTLA/B registers for advanced PWM pattern configuration.

#### **Enable port**

An additional component port is created if **Enable port** is set to Show. Applying a signal  $= 0$  to this port sets the PWM channel(s) to passive. This feature is not available in case of an AQ-based **Sequence** configuration.

### **High Resolution**

#### **High resolution duty cycle**

If enabled, PWM will use HR module to achieve high resolution duty cycle.

#### **High resolution period**

If enabled, PWM will use HR module to achieve high resolution period.

#### **High resolution dead time**

If enabled, PWM will use HR module to achieve high resolution dead time.

### Shadowing

#### Compare load

Specifies when compare register values are applied.

#### Rising-edge delay load

Specifies when variable dead time rising-edge delay values are applied.

#### Falling-edge delay load

Specifies when variable dead time falling-edge delay values are applied.

### Protection

#### Powerstage protection

Allows a Powerstage Protection block, if present in the schematic, to control the PWM output(s).

### Sync

#### Synchronization impulse from

Selects the source of the synchronization impulse. When self synchronization is chosen, the phase shift of the first allocated PWM resource must set to 0. When enabled, the synchronization input must be connected to another PWM block, an External Sync or Comparator block.

#### Synchronization output

Enables or disables the synchronization output port. When Enabled, the output from this port can be used as a source of the synchronization impulse.

#### Peripheral synchronization output

Enables or disables the peripheral synchronization output port **P** and defines when the event is generated. This output serves as synchronization signal for the Comparator block.

### Events

#### ADC trigger

Configures the ADC trigger output.

#### ADC trigger divider

Determines how many events need to occur before an ADC trigger is generated.

**Task trigger**

Configures the control task trigger output.

**Task trigger divider**

Determines how many events need to occur before a Task trigger is generated.

**Offline only****System clock**

Provides the option to manually specify the system clock frequency used for the offline simulation of the component. If `Determine automatically` is selected, the system clock frequency is determined from the **Coder + Coder Options + Target** settings.

**System clock frequency (SYSCLK)[MHz]**

Defines the system clock frequency in MHz for offline simulation.

**Deprecated**

This tab contains deprecated settings and is normally disabled.

## PWM (Variable)

**Purpose** Generate a complementary PWM signal pair with a variable phase shift, variable frequency and synchronization options

**Library** TI C2000

### Description

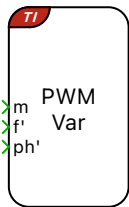

PWM (Variable)

The PWM (Variable) block generates a complementary PWM pair on a grouping of PWM channels that share a common synchronization impulse. The modulation index for each channel must be provided via the input signal **m**, which is a vectorized signal if the block uses more than one PWM channel. The carrier starts at 0 and varies between 0 and 1. During an offline simulation, the PWM block emulates the detailed behavior of the MCU ePWM peripheral very accurately.

The active/passive sequence of the PWM pattern is configurable. A positive sequence modulation begins with the active state at carrier underflow. In case of a negative sequence, the PWM pattern begins with a passive state.

The phase shift between the carriers of the individual PWM channels can be controlled with the vectorized input signal **ph'**. Each element of **ph'** specifies the phase delay of the PWM carrier with the same index. The delay is given in p.u. of the carrier period and must lie between 0 and 1.

The carriers of PWM resources are connected to a common synchronization signal, configured in the **Sync + Synchronization impulse from** setting. The synchronization signal can come from carrier zero count of the first PWM resource of the block, from another PWM (Variable) block, or from an external source using a GPIO pin. When an external GPIO synchronization signal is used an External Sync or Comparator block is required. Each PWM (Variable) block also has a synchronization output that can be connected to other PWM blocks.

Each group of PWM generators has the first channel configured as the primary channel and the other channels configured as secondaries. When a synchronization impulse is received, the primary channel transmits a synchronization signal to the secondary channels of the same block and other PWM blocks connected to the blocks synchronization output signal. When this happens, the ramp generators of the secondart channels are set to their initial values computed from the input signal **ph'** to achieve the desired phase shift.

The first element of the input signal *ph* corresponds to the phase delay of the primary channel and is relevant only when the synchronization source is another PWM block or an external GPIO. The phase delays between multiple

PWM (Variable) blocks are only accurate if the blocks have a common **Carrier frequency**.

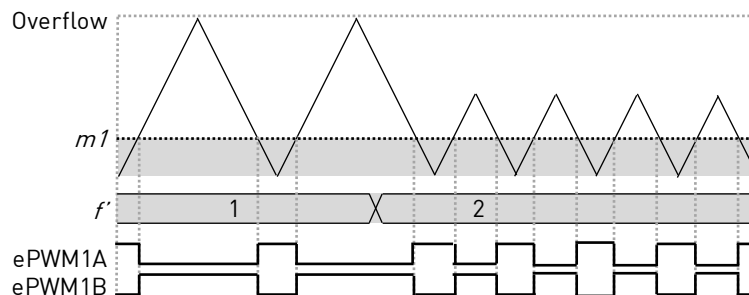

### PWM with frequency variation

Configure the **Frequency variation** parameter to enable the frequency input port  $f'$ . The figure above shows an example of the symmetric PWM carrier with frequency variation. The output frequency is given by  $f'$  multiplied by the **Carrier frequency** parameter. Note that all PWMs channels within one PWM (Variable) block share the same frequency input.

The PWM (Variable) block can configure independent interrupts to trigger the ADC start-of-conversion and the Control Task Trigger. Interrupts are synchronized with the PWM carrier and will occur at the carrier underflow, overflow, or underflow and overflow events. Underflow and overflow events correspond to PWM carrier reaching the carrier minimum and carrier maximum values.

Note that the variable frequency operation with synchronized and phase-shifted units can only be achieved on the newer TI processors, but not the TI 28335 and 28069 devices. On the TI 28335 and 28069 devices, either the variable frequency port ( $f'$ ) can be enabled or a non-zero phase-shift ( $ph'$ ) can be configured, but not both at the same time.

The PWM (Variable) block also supports **high resolution** modes for duty cycle, period, and dead time. Ordinarily, these values are rounded to the closest step achievable by the PWM clock. High resolution mode allows these values to be quantized at 256 times the resolution of the PWM clock, achieving much more accurate results at high switching frequencies. Utilizing this functionality will impose some notable limitations:

- Variable and custom **Sequence** may not be used with high resolution duty cycle or period enabled.

- Symmetrical **Carrier type** may not be used with high resolution period enabled.
- Duty cycle of 0 is unachievable with high resolution period enabled.
- **Compare load** in the **Shadowing** menu will be disabled when high resolution period is enabled (enforced to **Overflow**).

For expert users, this block offers fixed and variable Action-Qualifier (AQ) based sequence configurations to allow the generation of advanced PWM patterns. When an AQ-based sequence is enabled, the sequence value directly defines the PWM actions at specific timebase, compare and trip events. The lower 16-bits of the AQ value provided as a parameter, or at the **AQ** port, is written to the AQCTLA register and the upper 16-bits to the AQCTLA2 register.

---

**Note** For regular PWM sequences, the modulation input **m** specifies the relative duration of the active state. However, when AQ-based sequences are selected, the modulation input **m** sets the relative CMPA value.

---

Please refer to the TI Technical Reference Manual for more detailed information about the AQ Submodule and the AQCTLA and AQCTL2 register layout.

### Parameters

#### Main

##### Synchronization chain

Fixed for MCUs that have fixed synchronization chains, or Custom to configure arbitrary chains.

##### PWM chain [unit 1 ... unit N]

Configures an arbitrary synchronization chain. Note that some targets have limitations in terms of which chains are realizable.

##### Number of synchronized PWMs

The number of PWMs in the synchronization chain.

##### Group of 1, 2, or 3 PWM generator(s)

Selects the PWM resources that form the synchronization chain.

##### Carrier type

Selects the carrier waveform, either sawtooth or symmetrical.

##### Carrier frequency

The frequency of the carrier in hertz (Hz).

**Frequency tolerance**

Specifies the behavior when the desired carrier frequency is not achievable based on the system clock frequency.

**Frequency variation**

Enables or disables the frequency input port.

**Output****Dead time variation**

If enabled, an additional input port **d[r,f]** is displayed to allow variation of the rising-edge and falling-edge delays. This port expects:

- A vector of size 2 to set equal rising and falling delays for all channels, or
- A vector with a size equal to the number of PWM output channels, containing a sequence of d[r,f] pairs.

The units of the d[r,f] inputs are seconds.

**Dead time [s]**

Dead time is the delay between the rising and falling edges of the PWM output pair. Dead time is to be specified in seconds. This parameter is only applicable if dead time variation is disabled.

**Minimal dead time [s]**

The parameter specifies the minimal dead time when variable dead time is enabled.

**Polarity**

Defines the logical output corresponding to the active state.

**Enable port**

An additional component port is created if **Enable port** is set to Show. Applying a signal = 0 to this port sets the PWM channel(s) to passive.

**Sequence**

- A Positive sequence produces a PWM pattern that starts with the active state.
- The Negative sequence begins with the passive state, resulting in a pattern that is phase shifted by 180 degrees compared to the positive sequence.
- An additional component port **seq** is created if **Sequence** is set to Variable. Applying a signal > 0 to this port sets the sequence to positive.
- The Fixed AQ (Expert Mode) configures PWM patterns according to the **Fixed AQ sequence(s)** parameter, which is applied to the AQCTLA and AQCTLA2 registers as described above.

- An additional component port **AQ** is created if **Sequence** is set to Variable AQ (Expert Mode). As described above, the value at the **AQ** port is applied to the AQCTLA and AQCTLA2 registers for advanced PWM pattern configuration.

### **Enable port**

An additional component port is created if **Enable port** is set to Show. Applying a signal = 0 to this port sets the PWM channel(s) to passive. This feature is disabled in case of an AQ-based **Sequence** configuration.

### **Swap port**

An additional component port is created if **Swap port** is set to Show. Applying a signal = 1 to this port swaps the ePWMxA/B outputs.

---

**Note** Output swapping occurs after the dead time module. Consequently, no minimum dead time is guaranteed at the output swap transition, which could lead to shoot-through events.

---

### **Trip action port**

An additional component port **T** is created if **Trip action port** is set to Enabled. This port must be connected to the output of a Comparator target block. This option is only available in case of an AQ-based **Sequence** configuration.

### **Trip blanking**

This option allows the enabling and configuration of a trip blanking time during which the input of the **T** port is ignored. Trip blanking can be configured to occur at Underflow, Overflow, or both at Underflow and Overflow.

### **Trip blanking time [s]**

Specifies the duration of the trip blanking.

### **Trip blanking offset [s]**

Specifies an offset for the start of the trip blanking.

## **High Resolution**

### **High resolution duty cycle**

If enabled, PWM will use HR module to achieve high resolution duty cycle.

### **High resolution period**

If enabled, PWM will use HR module to achieve high resolution period.

**High resolution dead time**

If enabled, PWM will use HR module to achieve high resolution dead time.

**Shadowing****Compare load**

Specifies when compare register values are applied.

**Rising-edge delay load**

Specifies when variable dead time rising-edge delay values are applied.

**Falling-edge delay load**

Specifies when variable dead time falling-edge delay values are applied.

**Protection****Powerstage protection**

Allows a Powerstage Protection block, if present in the schematic, to control the PWM output(s).

**Sync****Synchronization impulse from**

Selects the source of the synchronization impulse. When self synchronization is chosen, the phase shift of the first allocated PWM resource must set to 0. When enabled, the synchronization input must be connected to another PWM block, an External Sync or Comparator block.

**Synchronization output**

Enables or disables the synchronization output port. When Enabled, the output from this port can be used as a source of the synchronization impulse.

**Peripheral synchronization output**

Enables or disables the peripheral synchronization output port **P** and defines when the event is generated. This output serves as synchronization signal for the Comparator block.

### Events

#### ADC trigger

Configures the ADC trigger output.

#### Task trigger

Configures the control task trigger output.

### Offline only

#### System clock

Provides the option to manually specify the system clock frequency used for the offline simulation of the component. If `Determine automatically` is selected, the system clock frequency is determined from the **Coder + Coder Options + Target** settings.

#### System clock frequency (SYSCLK)[MHz]

Defines the system clock frequency in MHz for offline simulation.

### Deprecated

This tab contains deprecated settings and is normally disabled.

## Quadrature Encoder Counter (QEP)

**Purpose** Count edges of a quadrature pulse train

**Library** TI C2000

### Description

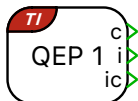

Counter

The Quadrature Encoder Counter counts edges which are generated from a quadrature encoder. The **A**, **B**, and **I** outputs of the encoder are connected to the QEP inputs of the C2000 target.

The block outputs the current counter value ( $c$ ), the index pulse ( $i$ ), and the latched counter value from the previous index pulse ( $ic$ ).

The counter counts up or down depending on the sequence of input pulses. The counter value will increase when the direction of rotation results in the rising edge of **B** following the rising edge of **A** and will decrease in the opposite direction of rotation. For each rising and falling edge of the **A** and **B** encoder output signals the counter will increment or decrement. Therefore the **Maximum counter value** must match the number of line pairs of the encoder multiplied by the number of counted edges per line pair minus 1. As an example, an encoder with 1024 line pairs would have a maximum count of 4095 since the QEP module counts all edges of **A** and **B**.

Once the counter reaches the value specified in parameter **Maximum counter value** it is reset to zero on the next detected edge in the positive direction. Vice versa, the counter is set to **Maximum counter value** when it is zero and detects an edge in the negative direction. If connected and configured by the **Counter reset method** parameter, the counter is also reset when the rising edge of the index input is detected.

### Parameters

#### QEP module

Selects the QEP peripheral module used.

#### GPIO numbers

Defines the A,B, and I GPIO pins assigned to the chosen QEP module.

#### Maximum counter value

The counter is reset to zero when it has reached the **Maximum counter value** and detects an input edge in the positive direction. The counter is set to the Maximum counter value when it is zero and detects an input edge in the negative direction.

#### Counter reset method

Selects whether the counter should be reset by a positive pulse on the index input or on overflow only.

# Read Probe

**Purpose** Provide read access to signal during a PIL simulation

**Library** TI C2000

**Description** During a PLECS processor-in-the-loop (PIL) simulation, a Read Probe allows PLECS to read variables in the embedded code.

For further details on the PIL simulation, refer to the PIL User Manual.

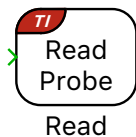

# Serial

**Purpose** Send data one character at a time via an SCI or UART link.

**Library** TI C2000

**Description** This block provides the basic functionality for transmitting and receiving characters over a serial communication interface (SCI) or universal asynchronous receiver/transmitter (UART).

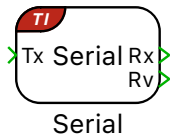

Characters are either sent at the base task rate or whenever the trigger condition is met. The trigger condition is set by the **Trigger Type** parameter when the block is configured for triggered execution. If the Serial block is unable to send a character due to the transmit (**Tx**) line being busy, the character will be dropped.

The block output **Rv** indicates that a new character has been received.

## Parameters

### Baud Rate

Communication rate in bits/s.

### Tx Mode

Selects between the default transmit behavior, which attempts to send whatever value is present at the **Tx** port at every execution step, and **Triggered** mode. **Triggered** mode enables the trigger port.

### Trigger Type

Configures the block trigger to behave as follows:

- **Rising Edge:** Data is sent when the trigger signal changes from 0 to a non-zero value.
- **Falling Edge:** Data is sent when the trigger signal changes from a non-zero value to 0.
- **Either Edge:** Data is sent when the trigger signal changes from 0 to a non-zero value or vice versa.
- **Signal High:** Data is sent when the trigger signal is a non-zero value.
- **Signal Low:** Data is sent when the trigger signal is 0.

### Receive (Rx) GPIO

GPIO number of receive pin.

### Transmit (Tx) GPIO

GPIO number of transmit pin.

## Sigma-Delta Filter Module

**Purpose** Demodulate signals transmitted by a sigma-delta ADC.

**Library** TI C2000

### Description

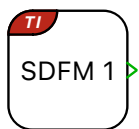

Sigma-Delta Filter Module

This block enables the use of the sigma-delta filter module (**SDFM**). The module requires a clock to synchronize the modulator and the demodulating filter. The C2000 MCU can produce a clock using the PWM peripheral, or the clock can come from an external device, but regardless of where the clock is generated, it must be physically connected to the designated **CLK** pin.

The module also has integrated comparators which can be run in parallel to the data filters. The comparators can be configured to disable PWM powerstages if high or low thresholds are crossed when used in tandem with a **Powerstage Protection** block.

### Parameters

## Configuration

### SDFM unit

Some C2000 MCUs have multiple SDFM peripherals that can be operated independently from each other. This parameter is used to select the desired unit.

### Channel

Each SDFM unit has four individual pairs of filters with their own clock and data lines. This parameter is used to select the desired filter.

### Clock source

For channels other than Channel 1, select whether to use a channel's dedicated clock input, or to share Channel 1's clock. Channel 1 must always be supplied a dedicated clock.

### Sample on

Select whether the SDFM is triggered on the rising or falling edge of the clock. This option is only accessible if a dedicated clock pin is being used.

### Pins

Selects appropriate pins. If the channel is using a dedicated clock, pins must be supplied as a pair in the format: **[CLK, DATA]**. If the channel is sharing Channel 1's clock, a data pin must be supplied as a single integer.

## Filtering

### Filter type

The SDFM module uses Sinc filters to convert a received pulse train into an analog value. There are four different types of Sinc filter to choose from – the higher the order of the filter, the greater the effective resolution of the resulting signal, at the cost of increased filter delay.

- **Sinc1:** A first-order Sinc filter.
- **Sinc2:** A second-order Sinc filter.
- **Sinc3:** A third-order Sinc filter.
- **SincFast:** A modified third-order filter which provides reduced latency at low OSR settings when compared to the Sinc3 option.

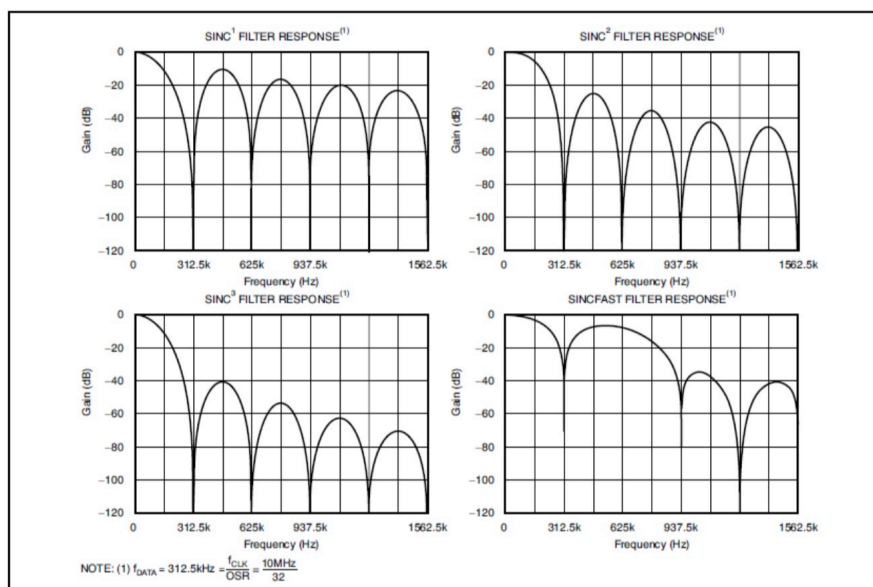

### Frequency Responses of Various Sinc Filters

Source: TI TMS320F28003x Technical Reference Manual

### Oversample rate (OSR)

Sets the filter's oversampling rate. Higher oversampling rates result in higher effective resolution, at the cost of decreased data rate.

### **Scale**

Scaling factor. Multiplied with filter's output.

### **Offset**

Offset factor. Added to filter's output.

## **Comparator**

This submodule is used to trigger high- or low-voltage threshold conditions from the same input stream as the main data filter, which can be configured to trip PWM modules using a separate **Powerstage Protection** block.

### **Comparator power stage protections**

Enables the comparator submodule.

### **Comparator filter type**

The comparator filters the SD pulse train using the same types of filter as the data filter module:

- **Sinc1**: A first-order Sinc filter.
- **Sinc2**: A second-order Sinc filter.
- **Sinc3**: A third-order Sinc filter.
- **SincFast**: A modified third-order filter which provides reduced latency at low OSR settings when compared to the Sinc3 option.

### **Comparator OSR**

The comparator oversampling rate. The comparator submodule uses lower oversampling rates than the data filter in order to reduce latency.

### **Emit trip signal**

Selects the desired trip signal to output when a threshold event is detected. The response to various trip signals is configured using a separate Powerstage Protections block.

### **Threshold type**

Determines which comparator thresholds will be active.

- **High**: High-voltage threshold active.
- **Low**: Low-voltage threshold active.
- **Window**: Both high- and low-voltage thresholds active.

### **High threshold**

Sets the threshold for detecting an high-voltage event. This value is configured using a decimal representation of the full-scale signal, with 0 representing 0 percent of the input range, and 1 representing 100%.

**Low threshold**

Sets the threshold for detecting a low-voltage event. This value is configured using a decimal representation of the full-scale signal, with 0 representing 0 percent of the input range, and 1 representing 100%.

**Offline Only****Simulation mode**

Because a real SDFM is typically clocked in the tens-of-megahertz range, simulating an actual modulator/demodulator pair requires a simulation step size which is too small for real-time simulation to be feasible. To address this, the SDFM module can be configured to run either an accurate-but-slow z-domain simulation, or a fast-but-compromised approximate simulation.

The most important difference between these two simulation modes are the way inputs are handled – the slow z-transfer setting expects to see a digital pulse train as would be expected at the input of a real SDFM, while the fast, approximate setting expects the **original, unmodulated signal to be monitored**. The fast setting simulates the latency and quantization of the **modulator paired with the demodulator**. From PLECS' perspective, the fast, approximate model produces a continuous signal, but this signal is quantized to the specific resolution produced by the selected OSR and filter type.

See the example model **sdfm\_offline\_examples.plecs** for a demonstration of how to use these different simulation modes.

**Modulator clock speed (MHz)**

Represents the clock speed of the modulated system. This is used to calculate the approximate delay of the system when using the fast, approximate simulation mode.

**Latency select (Fast approximation only)**

The approximate model calculates an approximate system latency to be used in the simulation. However, the true latency of any given system may vary from this approximation based on a wide variety of implementation details. For simulations in which this latency is critical, this setting can be used to provide a specific latency to use instead.

## SPI Controller

**Purpose** Implement SPI Controller connected to one or multiple peripherals

**Library** TI C2000

### Description

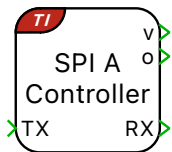

SPI Controller

The Serial Peripheral Interface (SPI) is a high-speed synchronous serial input/output device that allows a serial bit stream of programmable length (1 to 16 bits) to be shifted into and out of the device at a configurable bit-transfer rate. The SPI is usually used for communications between the MCU controller and external peripherals, or another controller.

The SPI is a controller-peripheral based interface with a single controller and one or more peripheral devices.

The interface consists of the following signals:

- **SPIPOCI** Serial data input (as controller in/peripheral out)
- **SPIPICO** Serial data output (controller out/peripheral in)
- **SPICLK** Shift-clock, generated by the SPI Controller
- **/SPICS** Chip-select or peripheral-enable signal, also referred to as SPIPTE. The chip-select signal is an active-low signal that enables the POCI and PICO ports of the SPI Peripheral

The SPI Controller block provides a clock signal (SPICLK ) which generates a configurable number of clock pulses during each simulation step. For both the peripheral and the controller, data is shifted out of the shift registers on one edge (rising or falling) of the SPICLK and latched into the shift register on the opposite clock edge. If the clock phase (CPHA) bit is configured to 1, data is transmitted and received a half-cycle before the SPICLK transition.

Multiple SPI Peripherals can be supported by a single controller through chip-select (/CS) signals. The figure below shows an example of a single SPI Controller with two SPI Peripherals.

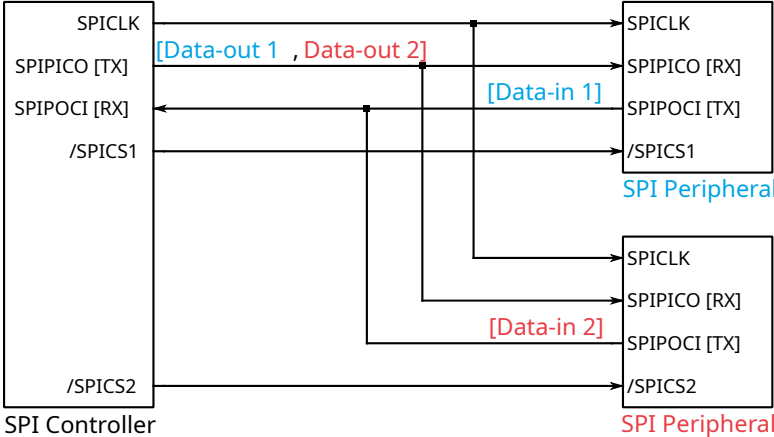

**SPI Controller with two SPI Peripherals**

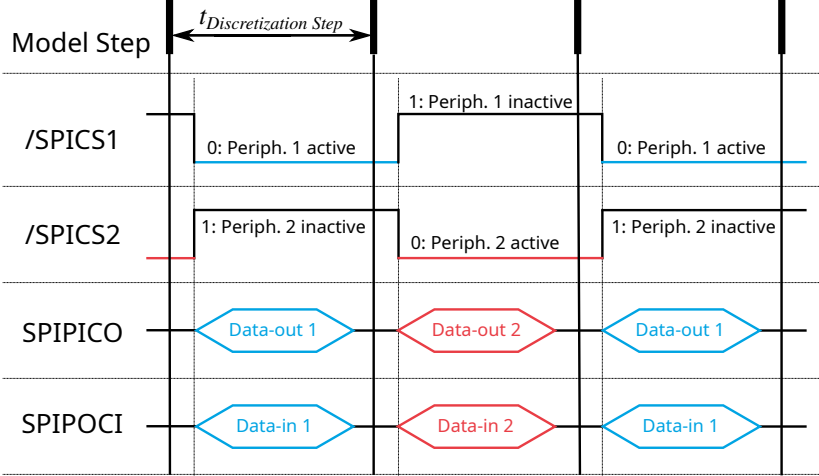

**An example of signal exchange between one SPI Controller and two SPI Peripherals**

The SPI Controller block exchanges data with only one SPI Peripheral per block execution step. If there are multiple peripherals, then data is exchanged over

multiple steps. For example, as illustrated in the figure above, during the first step, the controller enables SPI Peripheral 1 using the chip-select signal and transmits Data-out 1; at the same time the controller also receives Data-in 1 from the first peripheral. During the second step, after enabling SPI Peripheral 2, the controller transmits Data-out 2 and receives Data-in 2 from the second peripheral simultaneously. This process then repeats.

An output value of 1 at the **v** port indicates that valid data is sent to all the peripherals.

The data to be transmitted is provided at the input **TX** and the data received is available at the output **RX**.

- **TX**: For transmitting data to multiple peripherals, provide a vector with a length equal to the sum of the number of words per transmission per each peripheral. For example, in the figures above, if Data-out 1 is a packet of 4 words [1,2,3,4] and Data-out 2 is a packet of 3 words [16,17,18], then the input to the TX block is provided as a vector of 7 words [1,2,3,4,16,17,18].
- **RX**: Similarly, data from multiple peripherals is received as a vector with a length equal to the sum of the number of words per transmission per each peripheral. For example, in the figures above, if Data-in 1 is a packet of 4 words [21,22,23,24] and Data-in 2 is a packet of 3 words [36,37,38], then the output of the RX block is read as a vector of 7 words [21,22,23,24,36,37,38].

If the SPI Controller does not have enough time to complete the transmission before the block is executed again, the output **o** turns 1 to indicate an overrun error.

If an overrun error is being signaled at the **o** port of the SPI Controller, it is possible that the task with which the SPI Controller is associated executes too fast. In this case, either reduce the SPI Controller execution task rate or increase the SPI clock rate.

For example, if SPICLK is set as 180000 Hz, and is expected to transmit a packet of 4 words at 8 bits per word, then the time it would take to transmit one packet is

$$\frac{1}{180000} * 4 * 8 = 1.78 * 10^{-4} \text{ seconds}$$

In this case, the execution step size of the SPI Controller must be set to values greater than 0.178 milliseconds.

## Main

### SPI module

Selects the SPI module to use.

### Clock rate

Defines the SPI clock frequency (SPICLK), also known as the SPI Baud Rate, in Hz.

Refer to the TI technical reference for more information on the range of achievable SPI clock rates. This range is dependent on LSPCLK, a low-speed peripheral clock frequency, which is device-specific.

LSPCLK is derived by dividing the SYSCLK with a prescaler. SYSCLK is the main high speed clock of the CPU, configured in the Target tab of of the Coder Options dialog. The attached table shows the hard-coded values of LSPCLK for all the TI C2000 targets.

TI C2000 Target	LSPCLK prescaler
TI2806x	/4
TI28003x	/4
TI28004x	/4
TI2833x	/6
TI2837x	/4
TI2838x	/4
TI28P55x	/4
TI28P65x	/4

### Bits per word (1-16)

Defines the length of a single data word during transmission. The allowed length is 1 to 16 bits per word.

### Mode [CPOL, CPHA]

Defines four SPI clocking modes, controlled by clock polarity (CPOL) and clock phase (CPHA) bits. CPOL controls whether the clock signal is high (1) or low (0) when idle. CPHA controls whether data is shifted in and out on the rising or falling edge of the clock signal. The following table summarizes TI's convention of clock polarity and phase according to the standard SPI operating modes:

## SPI Clocking Modes

Mode	CPOL	CPHA	SPI Clock Scheme
SPI_MODE0	0	1	Rising edge with delay
SPI_MODE1	0	0	Rising edge without delay
SPI_MODE2	1	1	Falling edge with delay
SPI_MODE3	1	0	Falling edge without delay

### Serial GPIO numbers [PICO, POCI, CLK]

Selects the GPIOs to use for SPIPICO, SPIPOCI and SPICLK respectively.

### Offline simulation

Enables or disables data inspection in an offline simulation. If set to **enable**, terminals are added to the subsystem in the top-level schematic. If set to **disable**, no such terminals are added to the subsystem.

### Peripheral(s)

#### /CS GPIO number(s)

Selects the GPIOs to use for chip-select. Any GPIO, not just SPIPTE, can be configured to be a /CS signal. Provide a vector to configure multiple peripherals.

#### Words per transmission (vector for multiple peripherals)

Configures the number of transmitted data words in each simulation step. Provide a vector to configure multiple peripherals.

# SPI Peripheral

**Purpose** Implement SPI Peripheral

**Library** TI C2000

## Description

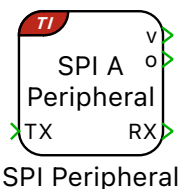

For a detailed description of the SPI protocol and signals, refer to the SPI Controller (see page 108) block.

The SPI Peripheral is synchronized to the clock generated by the SPI Controller. The SPI Controller uses a dedicated active-low chip-select signal that enables the POCI and PICO ports of the SPI Peripheral.

The data to be transmitted is provided at the input **TX** and the data received is available at the output **RX**. An output value of 1 at the **v** port indicates a valid data exchange with the SPI Controller.

If the SPI **RX** port receives new data before the previous data has been read, the existing data will be overwritten and lost. If this occurs, the output **o** turns 1 to indicate an overrun error.

There are two considerations to note when overrun errors occur:

- The controller is not allowed to start transmitting before the peripheral is up and running. If the peripheral is booting up while the controller is transmitting, then it may receive an incomplete first message, from which it will not be able to recover.
- In order to avoid overruns, the SPI Peripheral block must be executed faster than the rate at which the SPI Controller is sending data.

## Parameters

### Main

#### SPI module

Selects the SPI module to use.

#### Bits per word (1-16)

Defines the length of a single data word during transmission. The allowed length is 1 to 16 bits per word.

### Mode [CPOL, CPHA]

Defines four SPI clocking modes, controlled by clock polarity (CPOL) and clock phase (CPHA) bits. CPOL controls whether the clock signal is high (1) or low (0) when idle. CPHA controls whether data is shifted in and out on the rising or falling edge of the clock signal. The following table summarizes TI's convention of clock polarity and phase according to the standard SPI operating modes:

### SPI Clocking Modes

Mode	CPOL	CPHA	SPI Clock Scheme
SPI_MODE0	0	1	Rising edge with delay
SPI_MODE1	0	0	Rising edge without delay
SPI_MODE2	1	1	Falling edge with delay
SPI_MODE3	1	0	Falling edge without delay

### Words per transmission

Configures the number of transmitted data words in each simulation step.

### Serial GPIO numbers [PICO, POCL, CLK, /CS]

Selects the GPIOs to use for SPIPICO, SPIPOCI, SPICLK and /SPICS respectively.

### Offline simulation

Enables or disables data inspection in an offline simulation. If set to **enable**, terminals are added to the subsystem in the top-level schematic. If set to **disable**, no such terminals are added to the subsystem.

## Timer

**Purpose** Generate trigger signals for the ADC start-of-conversion and the control task using the CPU Timer

**Library** TI C2000

### Description

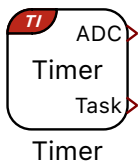

The Timer block configures the CPU Timer 0 interrupt to occur at the specified frequency. The timer interrupt can be used to trigger the ADC start-of-conversion or the Control Task Trigger.

The exact timer frequency may not be achievable based on the system clock frequency. The **Frequency tolerance** parameter allows automatically rounding to the closest achievable value when the exact timer frequency is unachievable.

### Parameters

#### Frequency

Defines the frequency of the timer in hertz (Hz).

#### Frequency tolerance

Specifies the behavior when the desired timer frequency is not achievable.

plexim  
electrical engineering software

---