

PLECS

DEMO MODEL

Space Vector Control of a Boost System

Last updated in PLECS 4.3.1

www.plexim.com

- ▶ Request a PLECS trial license
- ▶ Check the PLECS documentation

1 Overview

Space vector control is a popular technique used in the control of motor drives or three-phase rectifiers since it offers reduced switching losses and better utilization of the DC bus compared to conventional PWM control. This example model demonstrates space vector control of a three-phase boost-type rectifier.

Note This model contains model initialization commands that are accessible from:

PLECS Standalone: The menu **Simulation + Simulation Parameters... + Initializations**

PLECS Blockset: Right click in the **Simulink model window + Model Properties + Callbacks + InitFcn***

2 Model

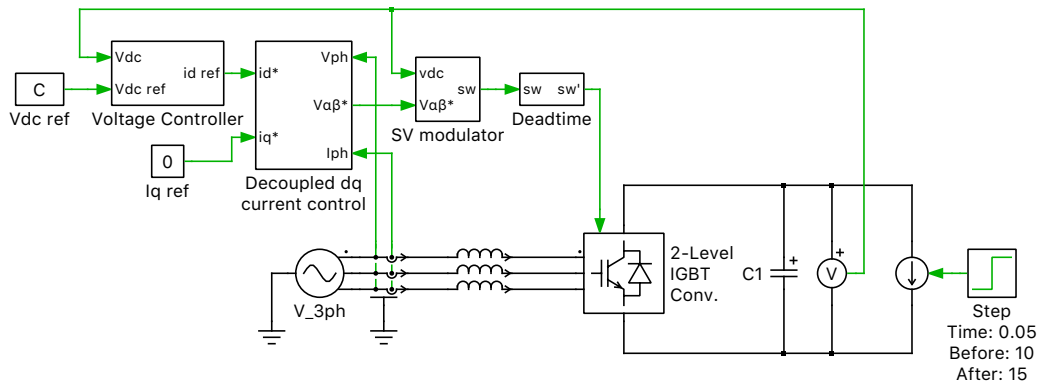

Figure 1: System model

2.1 Control

The control goals for the three-phase boost rectifier are to draw sinusoidal current from the input supply, v_n , and to regulate the output voltage, V_{DC} . Current control is achieved using an inner current control loop that measures the phase current, i_n , and controls the inductor-neutral voltage, iv_{n1} , to force the phase current to track its reference value. The current reference is provided by outer control loops that implement DC voltage and power factor control.

With space vector control, the inductor-neutral voltage is controlled as a vector quantity in the $\alpha\beta$ or dq domains. In this example, control is performed in the dq domain. The advantage of dq control is that AC quantities become DC quantities in the dq domain. Thus no tracking error exists when using a PI controller to regulate the AC input current.

The reference AC voltage vector is generated by time-averaging the available switching vectors. Two popular modulation strategies have been implemented in the space vector modulator: an optimal modulation strategy that minimizes the switching losses and a symmetrical modulation strategy that minimizes the THD. A deadtime component has also been included to simulate the effect of switching delay when changing the switch state of a rectifier leg.

This model uses the Space Vector PWM block in the **Control + Modulators** component library, which is implemented using a C-Script block under the mask of the subsystem. The code-based implementation can be viewed to study the definition of the switching matrices, reference vector magnitude and angle calculations, sector detection logic, and calculation of relative on-times.

Revision History:

PLECS 4.3.1 First release

How to Contact Plexim:

☎	+41 44 533 51 00	Phone
	+41 44 533 51 01	Fax
✉	Plexim GmbH Technoparkstrasse 1 8005 Zurich Switzerland	Mail
@	info@plexim.com	Email
	http://www.plexim.com	Web

PLECS Demo Model

© 2002–2021 by Plexim GmbH

The software PLECS described in this document is furnished under a license agreement. The software may be used or copied only under the terms of the license agreement. No part of this manual may be photocopied or reproduced in any form without prior written consent from Plexim GmbH.

PLECS is a registered trademark of Plexim GmbH. MATLAB, Simulink and Simulink Coder are registered trademarks of The MathWorks, Inc. Other product or brand names are trademarks or registered trademarks of their respective holders.